



Landscape Designing Presentation



A L D S

ARVIKA LANDSCAPE DESIGNS SOLUTIONS PVT. LTD.

An ISO 9000:2015 Certified Company

Landscape Designing Turnkey Projects Plants Nursery
Vertical Gardens Water bodies Irrigation systems

Office Add: A-1, Suparshwanath Soc, Market Yard Road, Pune-411037.

Regd. Add.: A-1104, Swayambhu Hills Soc, Nr. Gangadham chowk, Kondhawa-Bibwewadi Road, Pune-411037.

Nursery : Morewasti, Nr. Indraprastha Lawns, nr. ICAR, Solapur road, Pune.

Chennai office : MGR Nagar bus stand, Karasangal, Vandalur - Oragadam - Walajabad Rd, Padappai, Tamil Nadu-601301.

Land line : 020 29510985 Cell : 9822863958

email : arvikasolutionspune@yahoo.com website : www.arvikasolutions.com

Scope of Work as Landscape Designer

Inputs from client to start the work

1. To provide plan with Green area marked for proposed landscape area which is in tune with completion certificate.
2. To provide norms for designing (like compliance as per Industrial area or Green building certification)
3. To provide detailed requirements for aspects like water body, recreation areas, pathways and or all requirements which client intend to incorporate in landscape area.
4. To provide additional inputs like, location of water source which is required for designing of irrigation system.
5. All information related to availability of soil, water & murrum.
6. To provide information which has to be considered as do and donts in designing. Like if food industry will not allow to plant fruit trees to keep birds away.

After receipt of above information, we provide below deliverables

1. Optional layouts taking into considerations aspects of soft scape, hard scape & water scape. These aspects also consider requirements towards completion certifications.
2. After finalisation of layout considering major inputs of client, preparation of final layout.
3. Based on final layout, providing material options with combinations of soft scape & hard scape. (in forms of photographs or actual material)
4. Providing approximate budgets with 2-3 combinations to arrive at approximate final layout with budget.
5. Preparation of presentation drawings to have final design with final budget.
6. Preparation of Bill of Quantities.
7. Providing estimate based on Bill of Quantities.
8. Preparation of detailed working drawings and information about material to be used for entire scope of work for soft scape, hard scape, water body, civil work & irrigation system.
9. Preparation of tender documents.
10. After offering work by client to competent contractors, explaining the projects & drawings at site.
11. Based on work order terms, providing service of partial supervision to ensure quality of work executions.

Till now we have completed more than 50 industrial, 25 Residential, 15 Commercial, 5 Hospitality & few more spaces.



Landscape Designing Industrial Projects



A L D S

ARVIKA LANDSCAPE DESIGNS
SOLUTIONS PVT. LTD.

An ISO 9000:2015
Certified Company

Site Details

Client : Schindler India Pvt. Ltd.

Site : Factory Premises At Midc Chakan, Dist. Pune

Area Under Scope Of Work : 30,000 Sqm

Duration : 2013-2014

Project Highlights

Scope Of Work : Designing As Per IGBC Norms, Soft Scape, Water Body, Irrigation System & Execution Of Entire Project

Soil : 50% At Site Black Cotton Soil + 50% Garden Soil

Irrigation System : Installed In Entire Area

Water Body : Installed

This Project Has Obtained IGBC Platinum Certification



A L D S

**ARVIKA LANDSCAPE DESIGNS
SOLUTIONS PVT. LTD.**
An ISO 9000:2015
Certified Company

Plantation Plan For Entire Area

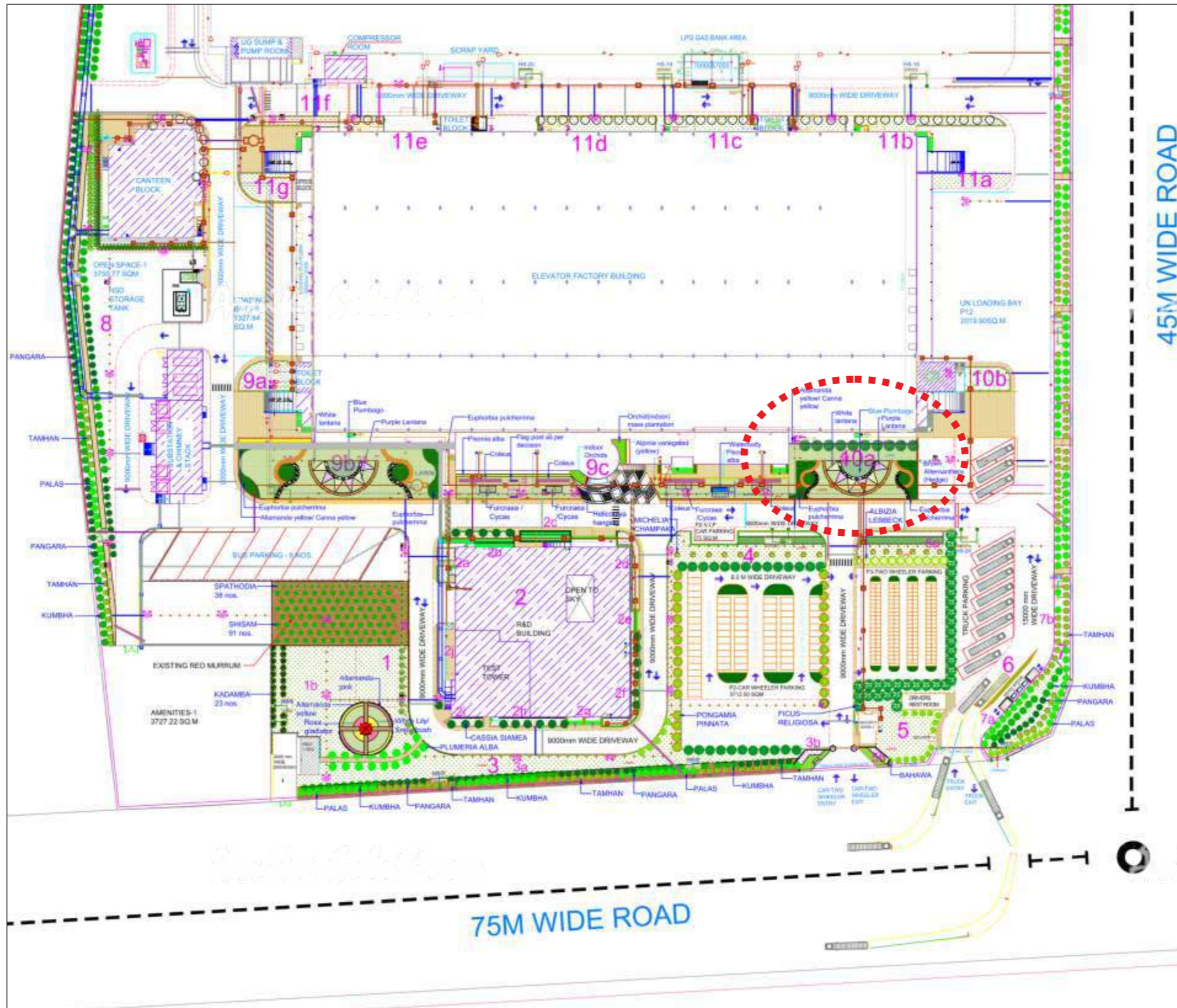

SYMBOL	BOTANICAL NAME	COMMON NAME
	Lagerstroemia lanceolata	Tamhan
	Carvea arborea	Kumbha
	Erythrina suberosa	Pangara
	Busea monosperma	Palas
	Spathodia	Fountain tree
	Dalbergia latifolia	Shisam
	Cassia siana	Cassia florida
	Cassia fistula	Bahawa
	Ficus religiosa	Pimpal
	Pongamia pinnata	Karanj
	Micheia champaca	Sonchaia
	Albizia lebeck	Shirah

Note : Below Tree no Lawn only Drip line

KEY :

- HARDSCAPE
- RED MURRUM
- LAWN

PLANTATION PLAN for SCHINDLER INDIA PVT LTD,
 Plot No: D-234 (Part),
 Chakan Industrial Area,
 Phase – II, Village-Warale,
 Tal-Khed, Dist-Pune.



ADD: 'ASHWINTI', A-1, Suparshwanath Soc.,
 Market Yard Rd. Pune-411037.
 Phone No. 020 65223600 Cell No. 09372227271.
 e-mail : arvikasolutionspune@yahoo.com
 Website : www.arvikasolutions.in

Plantation Plan for Individual Area

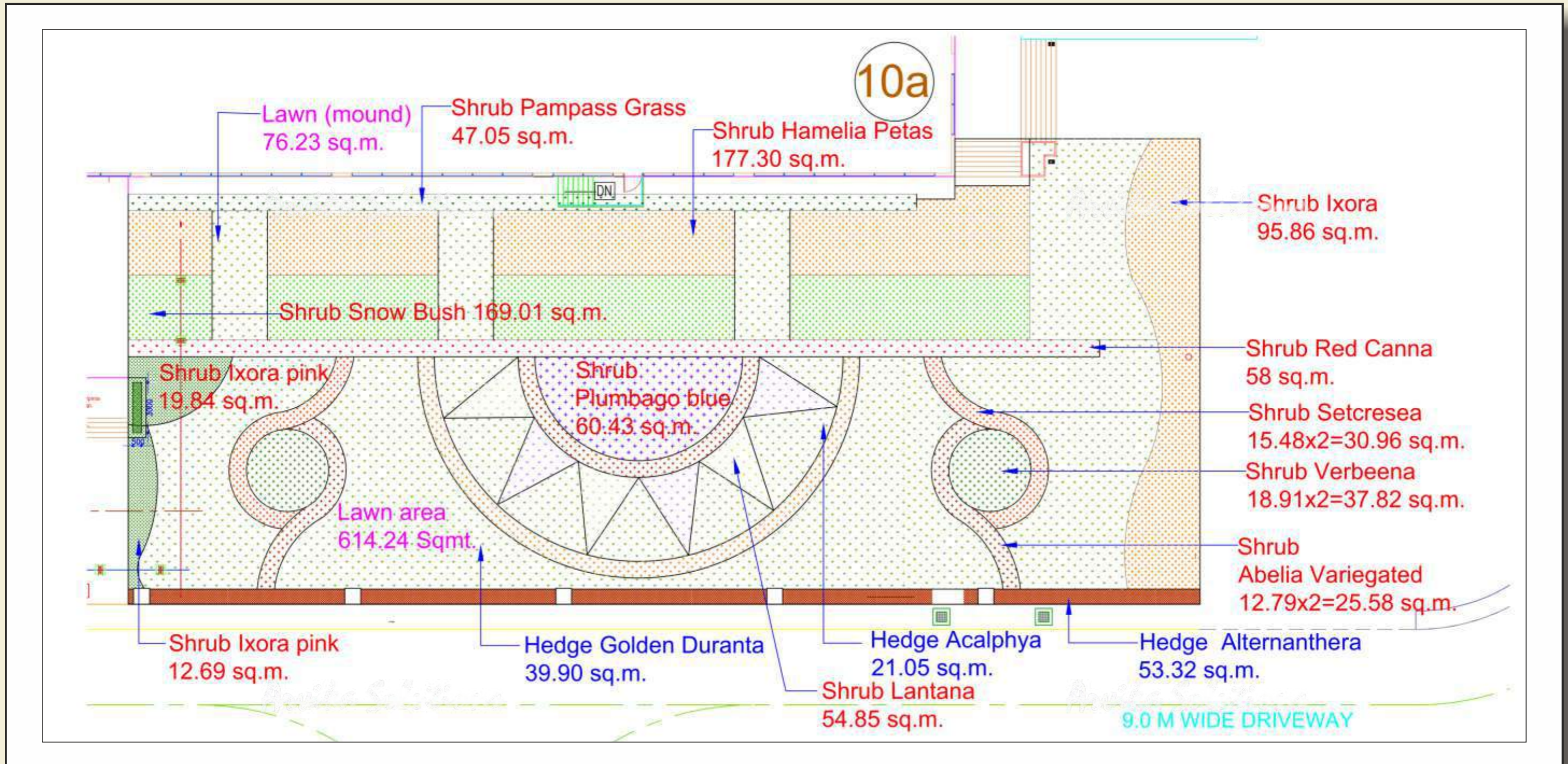

Landscape Line out

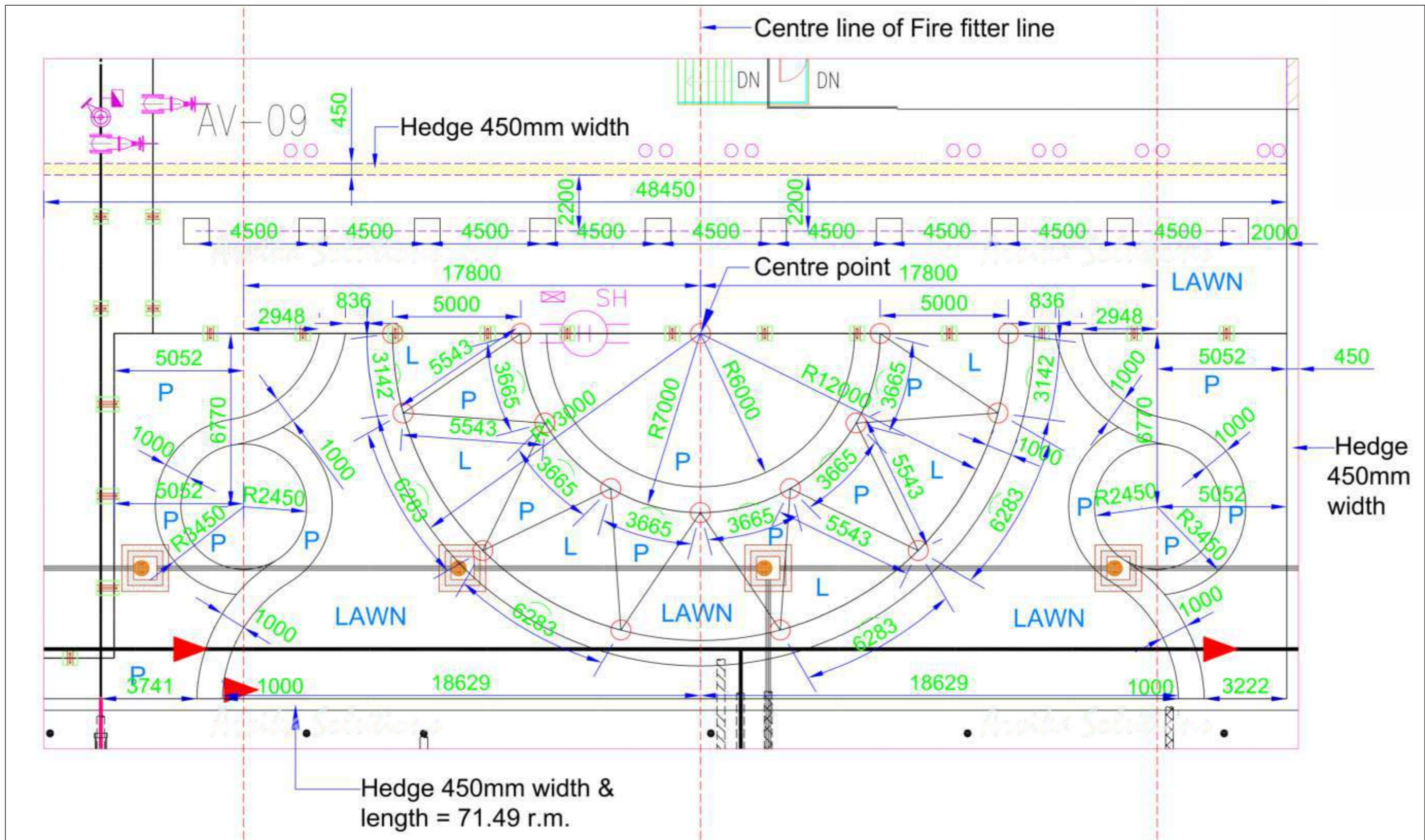

Details of Plants to be used

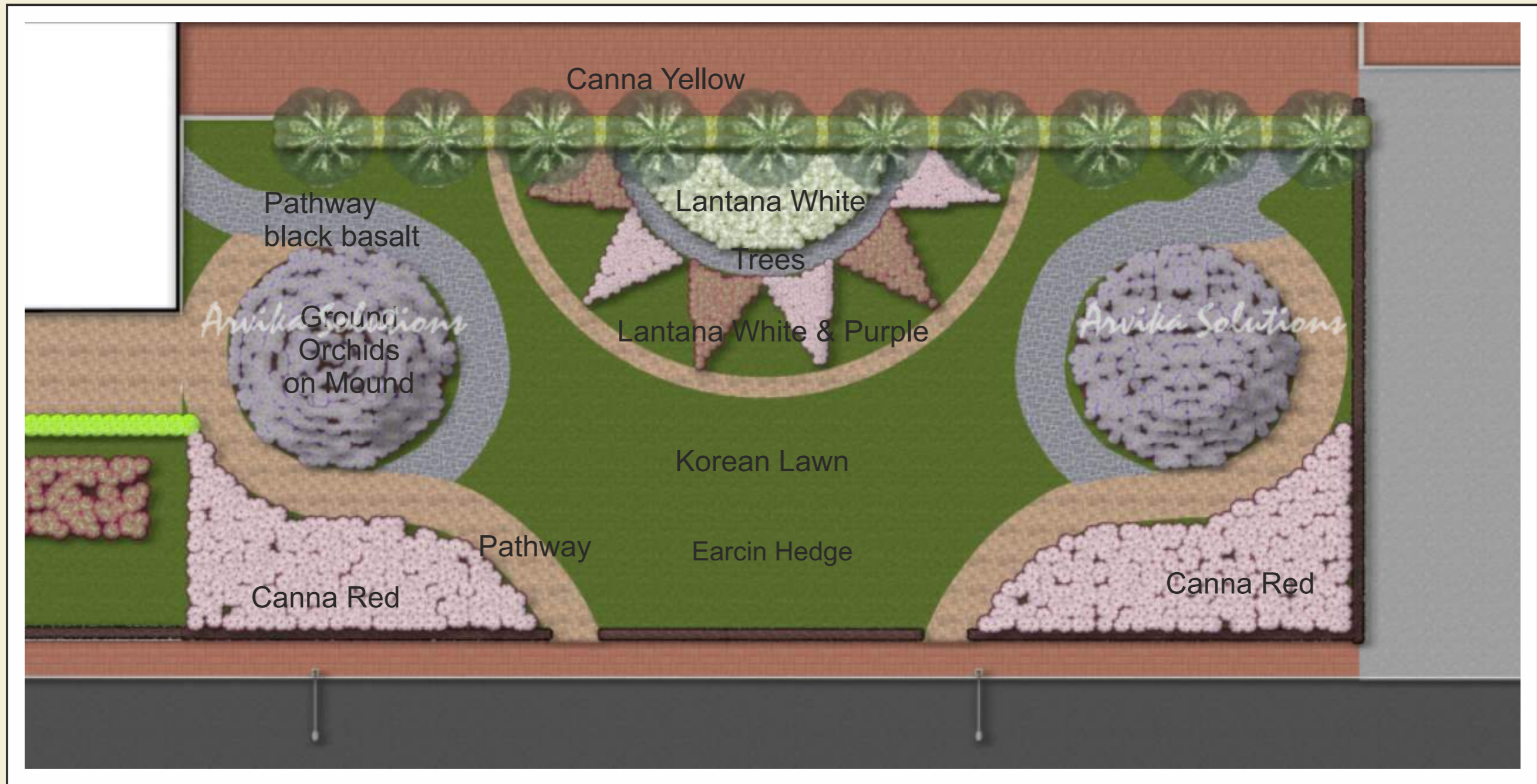

Canna Red



Ground Orchids



Canna Yellow



Lantana White



Lantana White & Purple



Earcin Hedge

Rendered Images



Rendered Images



Irrigation System Plan

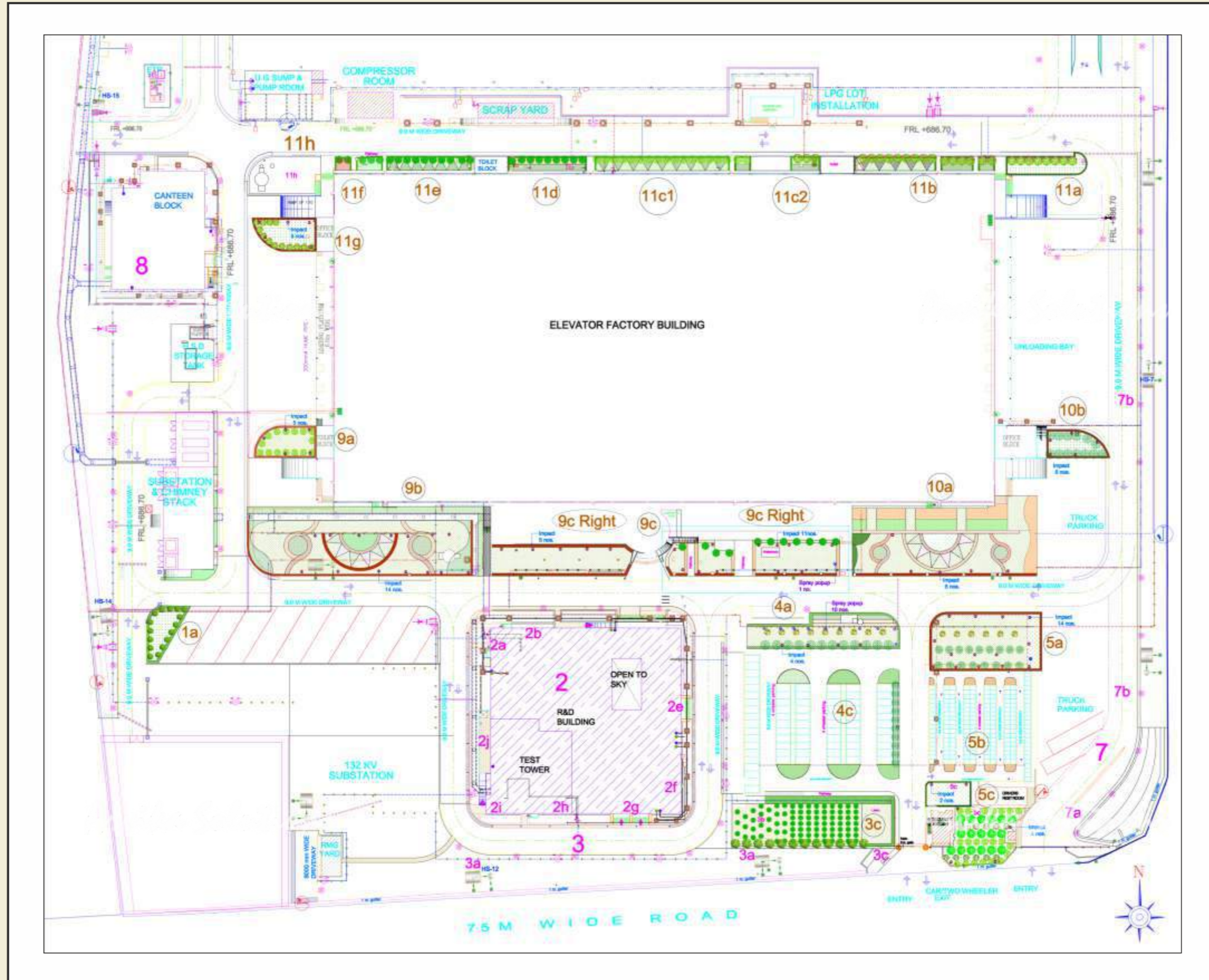

Working Drawings For Water Body

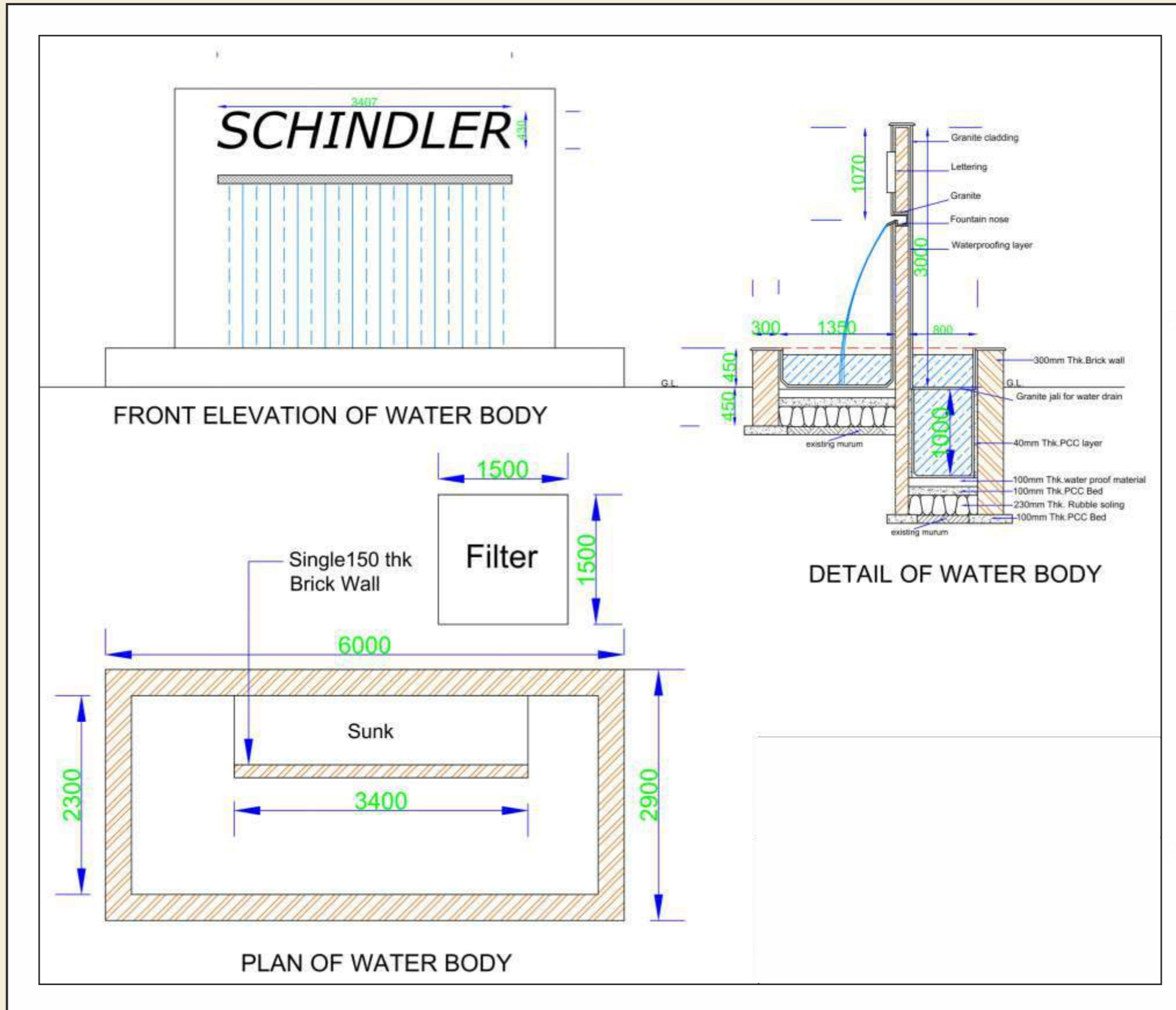

Working Drawings For Water Body

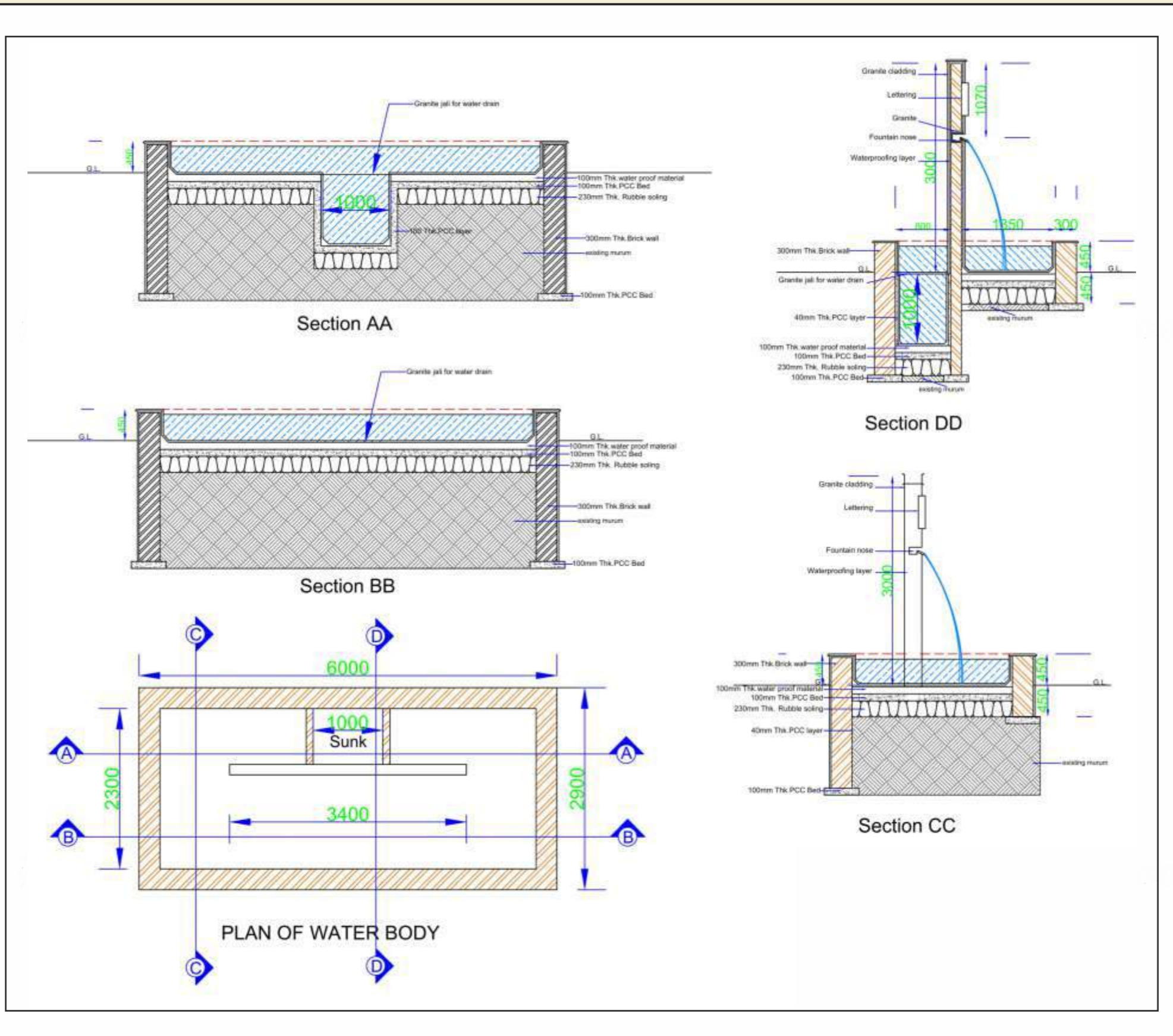

Site Photographs



Site Photographs

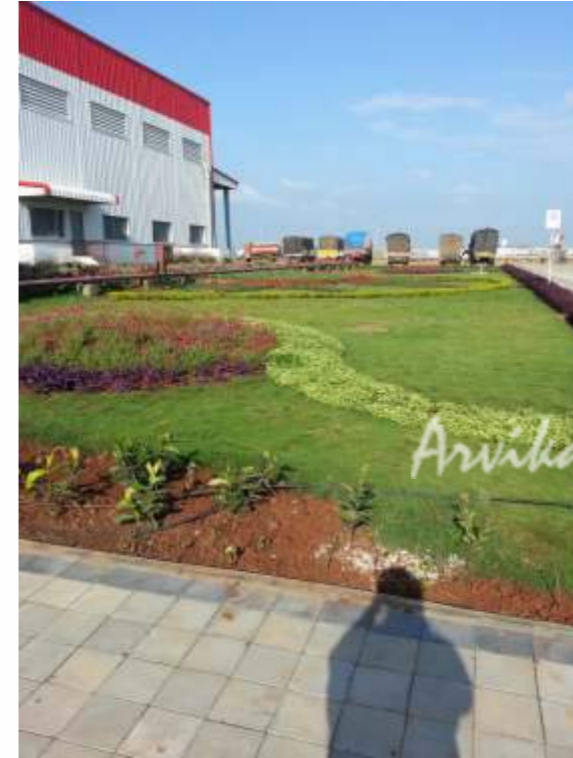

Site Photographs



Site Details

Client : PPG Asian Paints Pvt. Ltd.

Space under scope of work : Industrial premises

Area under scope of work : 20,000 sqm

Scope of work : Landscape Designing, Soft scape, water body & irrigation system

Duration : June 2019



**ARVIKA LANDSCAPE DESIGNS
SOLUTIONS PVT. LTD.**
An ISO 9000:2015
Certified Company

Green Area Marked for proposed landscape area

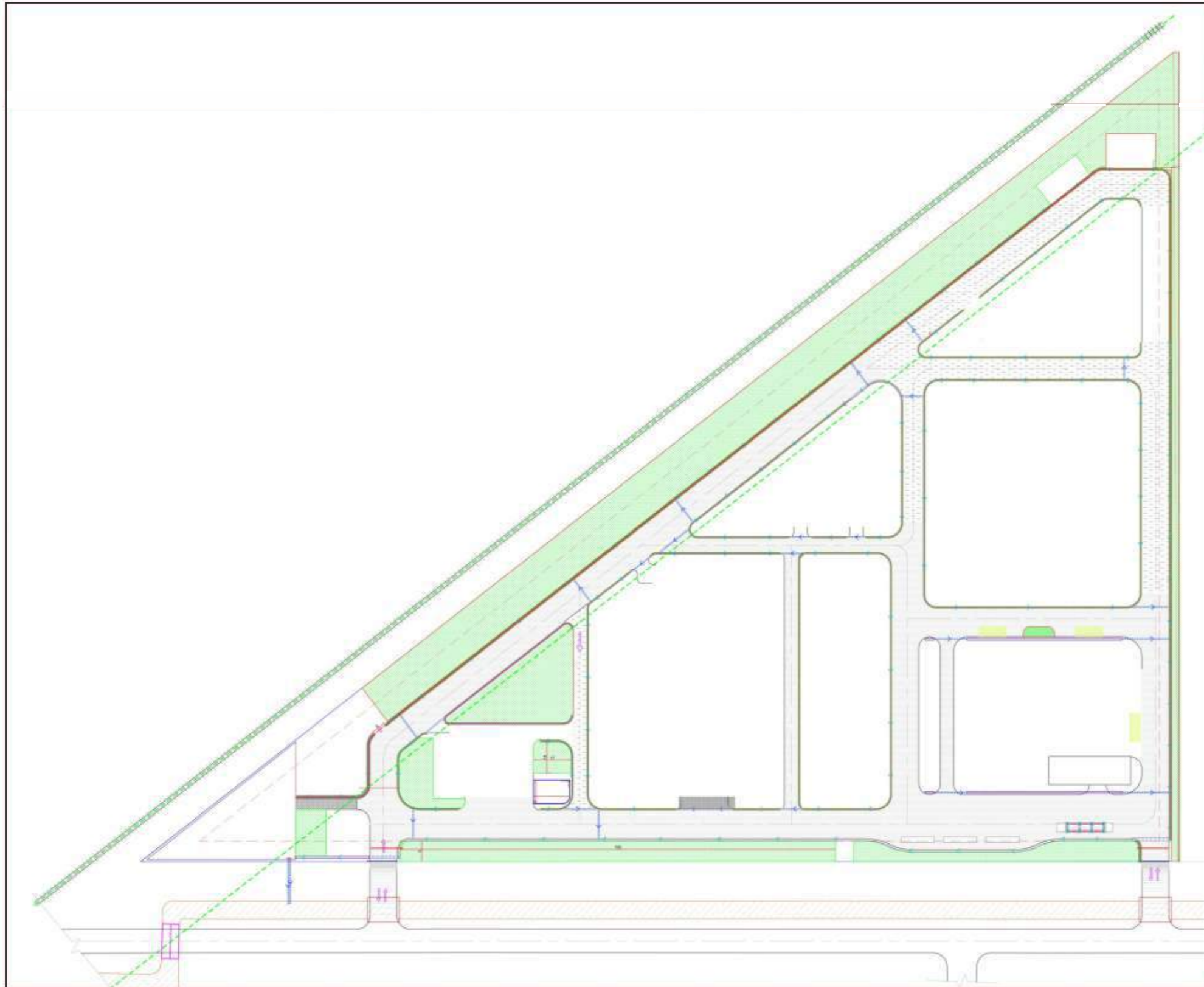

Plantation Plan Option 01

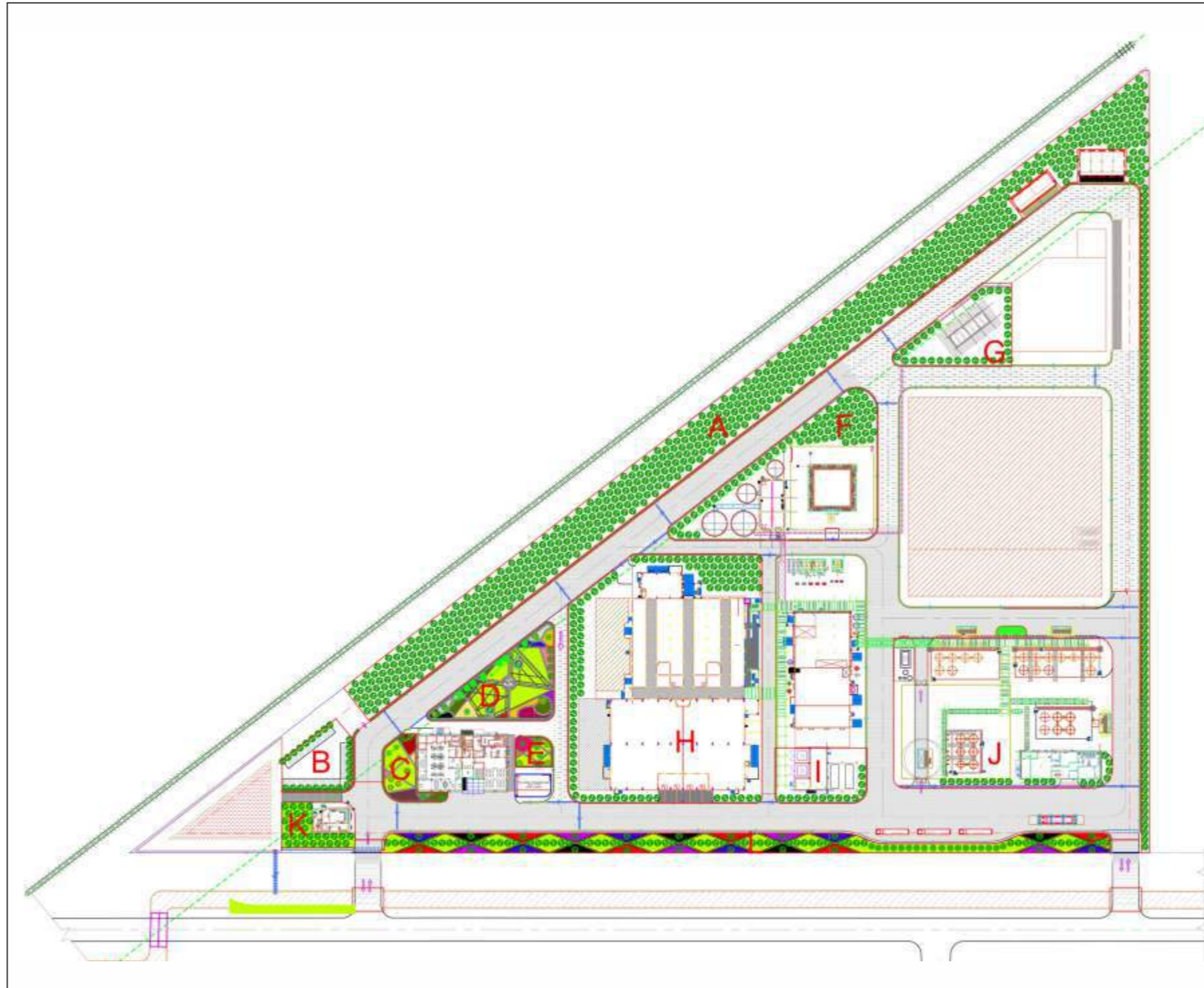

Plantation Plan Option 01

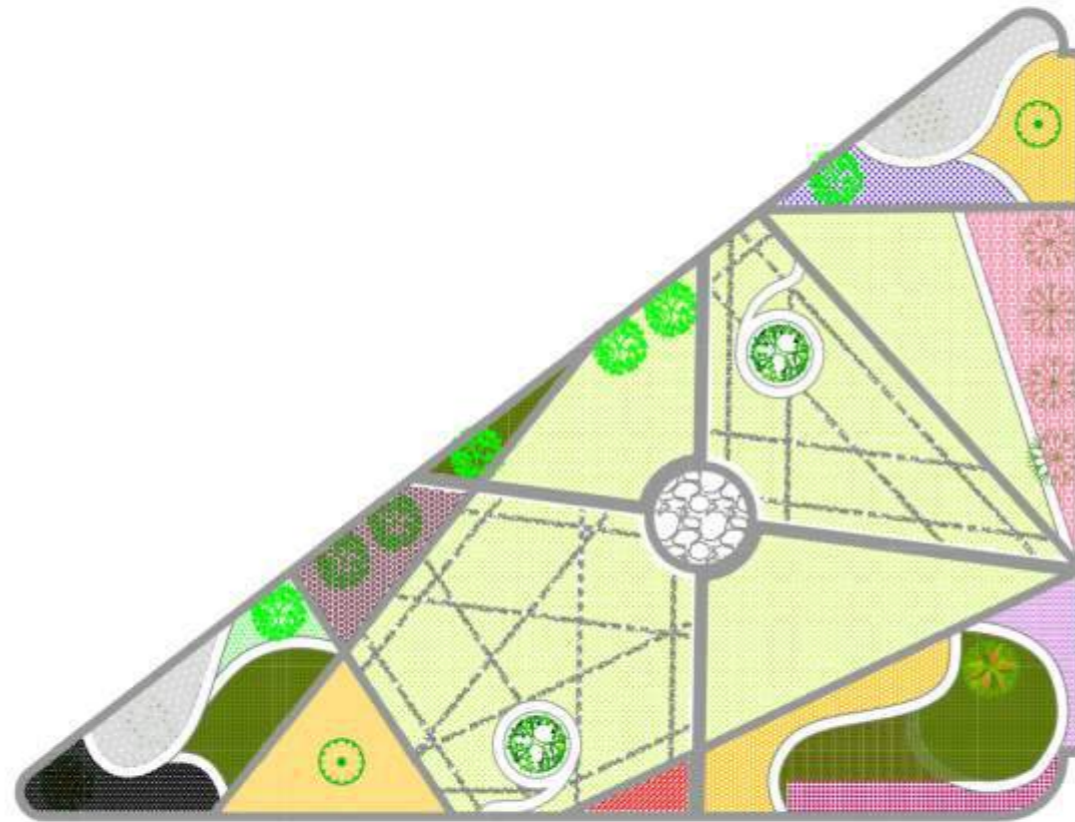

- Index**
- Lawn
 - Wedelia
 - Mini Tagar
 - Lantana Blue
 - Mondo Grass
 - Chlorophytum
 - Giant Lily Purple
 - Lantana White
 - Setcreasea
 - Allamenda Yellow
 - Lantana Red
 - Rhoeo
 - Hemigraphys
 - SpathodiaTree
 - Plumeria Tree
 - Bahunia
 - Bottle Brush
 - Kadamba
 - Circular area for Statue
 - Pathway
 - Shahabad Stone Hardscape

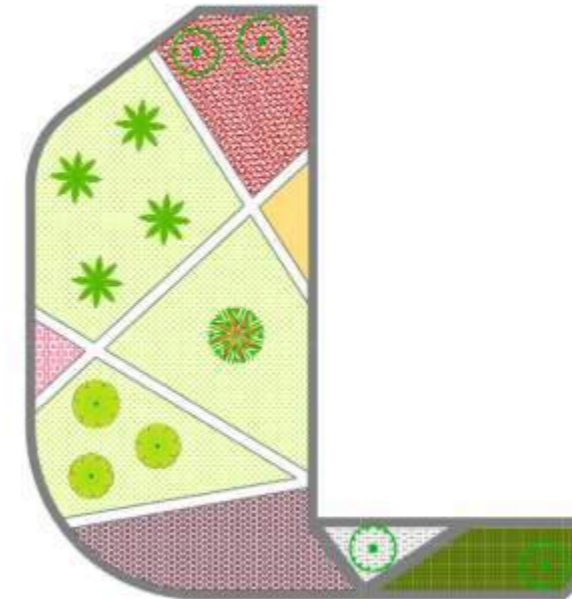

- Index**
- Ixora Red
 - Spiderlily
 - Lawn
 - Allamenda Yellow
 - Chlorophytum
 - Hemigraphys
 - Rhoeo
 - Spathodia
 - Nerium Red Olendra
 - Plumeria Rendra
 - Ficus Black
 - Pathway



- Index**
- Lawn
 - Heliconia Lady Diana
 - Ixora Pink
 - Setcreasea
 - Wedelia
 - Terminalia
 - Ficus Black
 - Pathway

Rendered Images



Plantation Plan Option 02

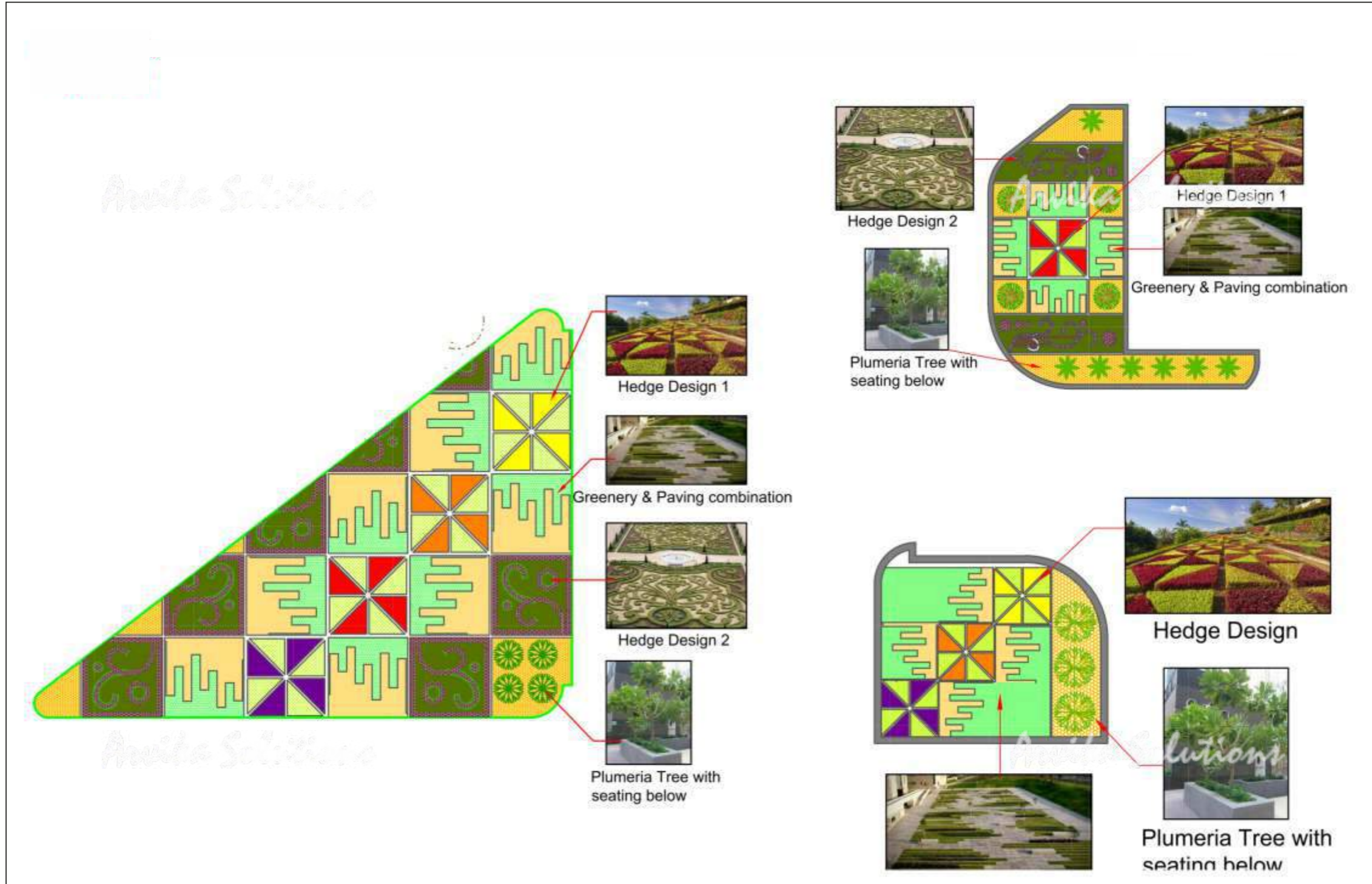

Presentation Plan Option 03



Rendered Images

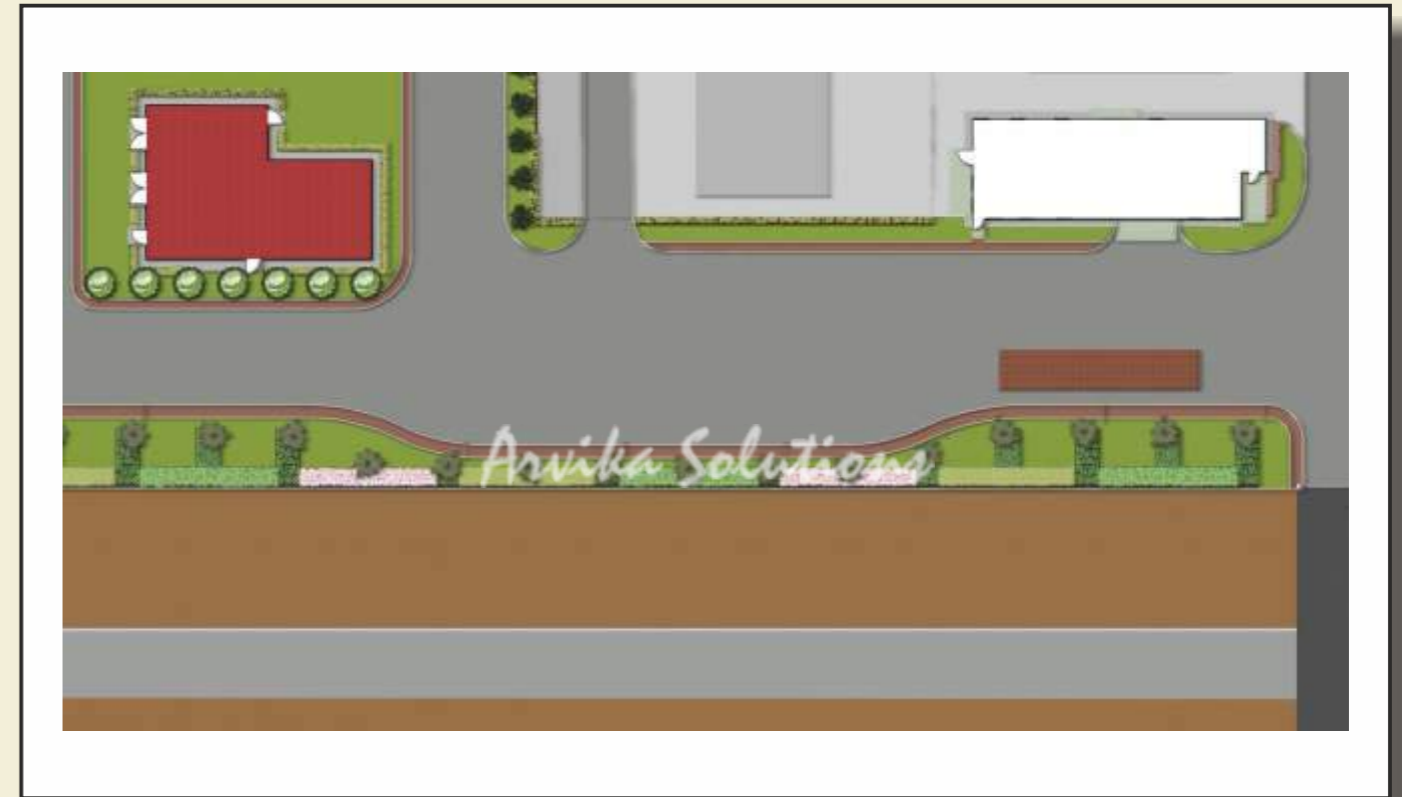

Rendered Images



Rendered Images



Rendered Images



Rendered Images



Irrigation Plan

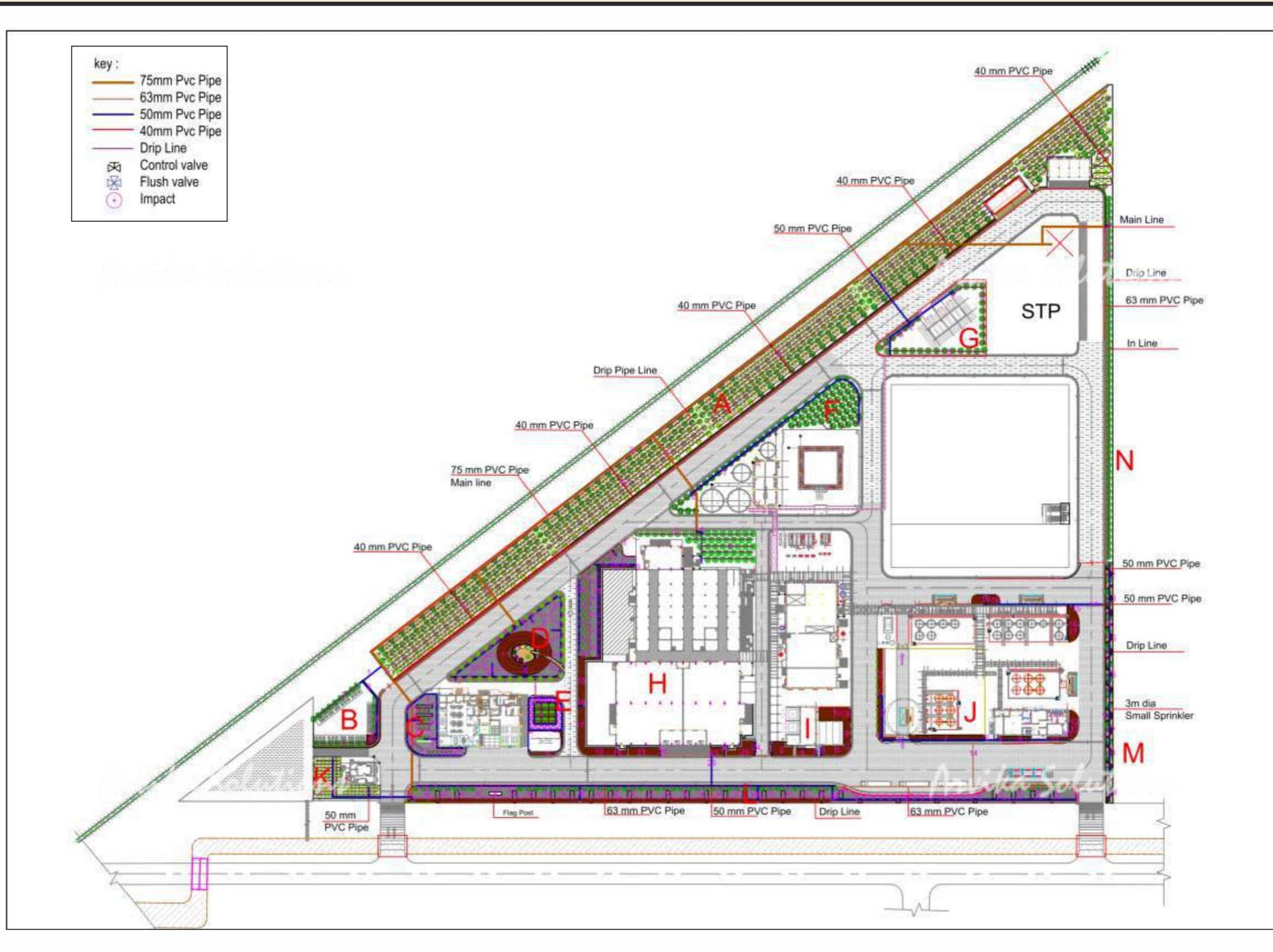

The premises is in the rainy area. It is already running factory which is established more than 15 years ago. Plantation done at that time was excellent & has flourished very well. The company has their own horticulturist. The client came up with an idea to prepare layout at their end and asked us to design in newer ways with liberty to design with our own thought process of areas of soft scape, Civil works & water scape.

The project is under IGBC. So norms has to be followed. The area had multiple levels including lower ground level, higher ground level & terrace. The selection of plants had to be great as they were bore of existing plants as they have been seeing for long duration. The client was very much keep to utilise terrace on regular basis.

Since it is industrial landscape we had to design with balance of cost aspect and IGBC norms. We had reduced use of hard scape & incorporated shrubs & ground cover more. We have selected partially less water requiring plants, yet should have beauty of either colours, fragrance, leaves or trimming shape. We had sectorial used plants, like bands of colours, fragrance of spices, levels of plants, cutting shaping with height variations etc. There was beautiful run off of rain water which we have given path through arranged boulders water body to give natural look. We have provided few areas which are externally placed which were originally designed to be indoor. Like seatings in reception areas, which are generally indoor, we had given option to seat outside.

Owners we highly keep to utilise the terrace in best possible ways. Again designing had to be sustainable. We have designed several seating areas for individual , multiple & as auditorium. These were below trees, under pergola etc. Longer but small in areas water body is designed to have live element on terrace.

This was the project which was challenged at all stages by horticulturist (Selection of plants), existing staff (for newer look), minimising use of natural resources like hard scape, water for irrigation.

Site Details

Client : Confidential

Space under scope of work : Factory premises & Terrace garden

Area under scope of work : Ground level 6,000 sqm &

Terrace 2,000 qsm

Scope of work : Designing on pre designed layout as per IGBC of Soft scape, water body, Civil works & irrigation system

Duration : Oct 2019



**ARVIKA LANDSCAPE DESIGNS
SOLUTIONS PVT. LTD.**

**An ISO 9000:2015
Certified Company**

Plantation Plan

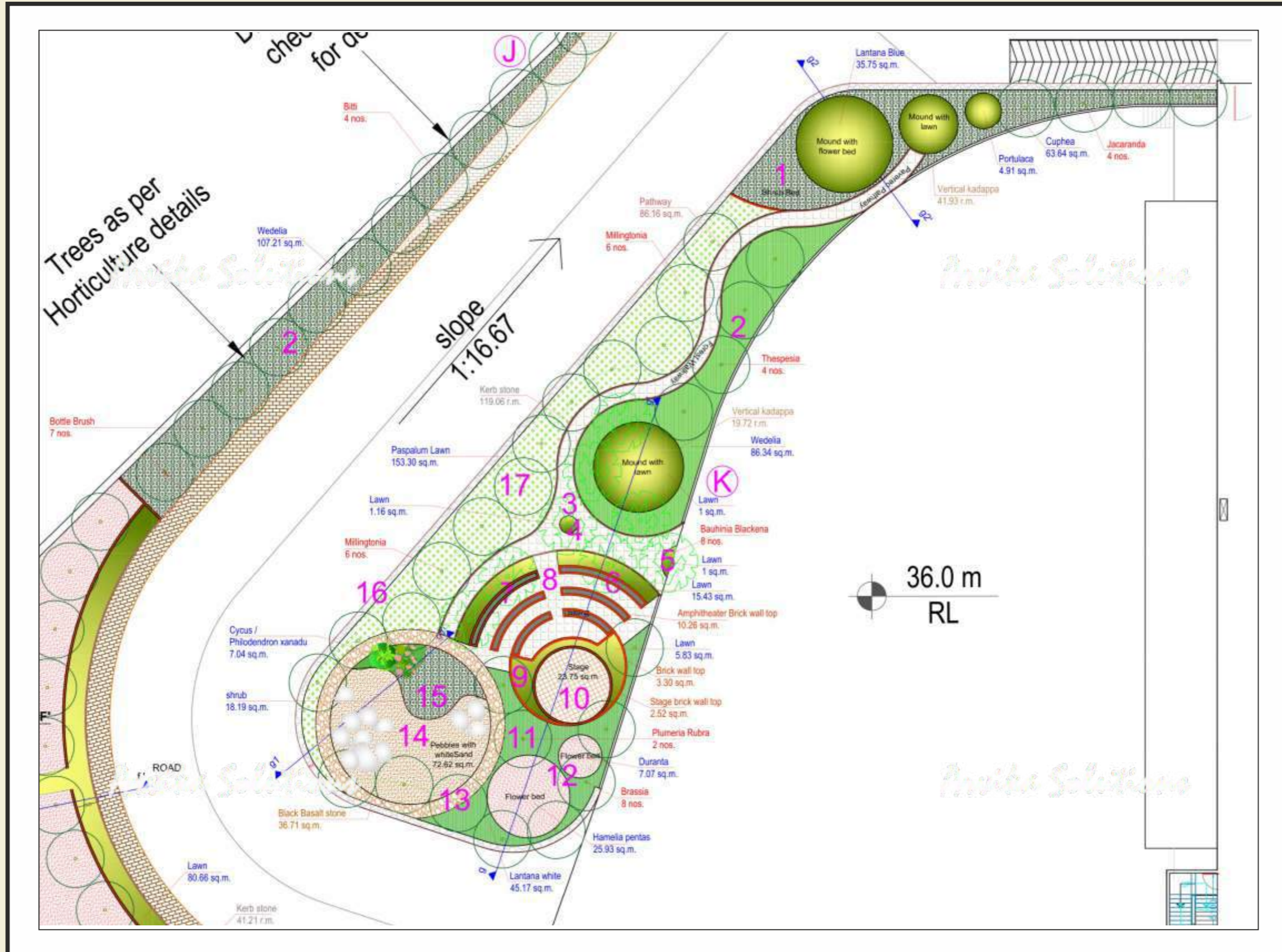

Rendered Views



Rendered Views



Plantation Plan

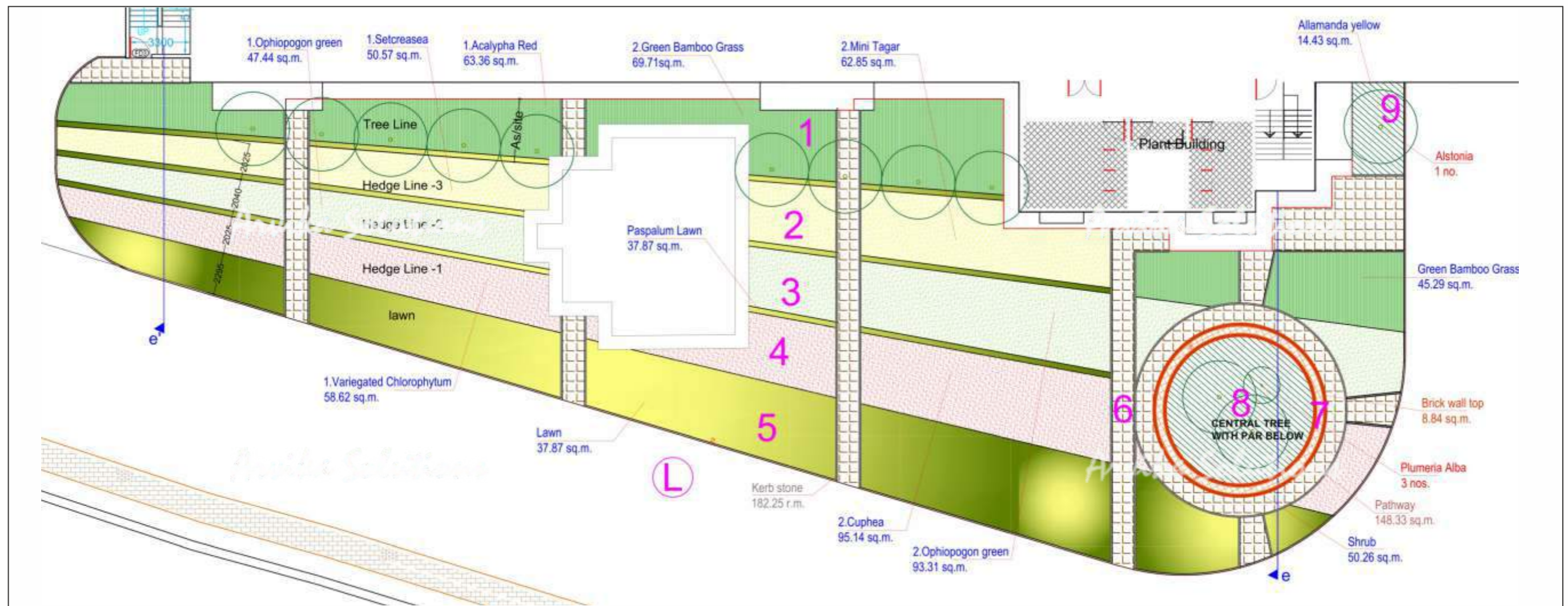

Rendered Views

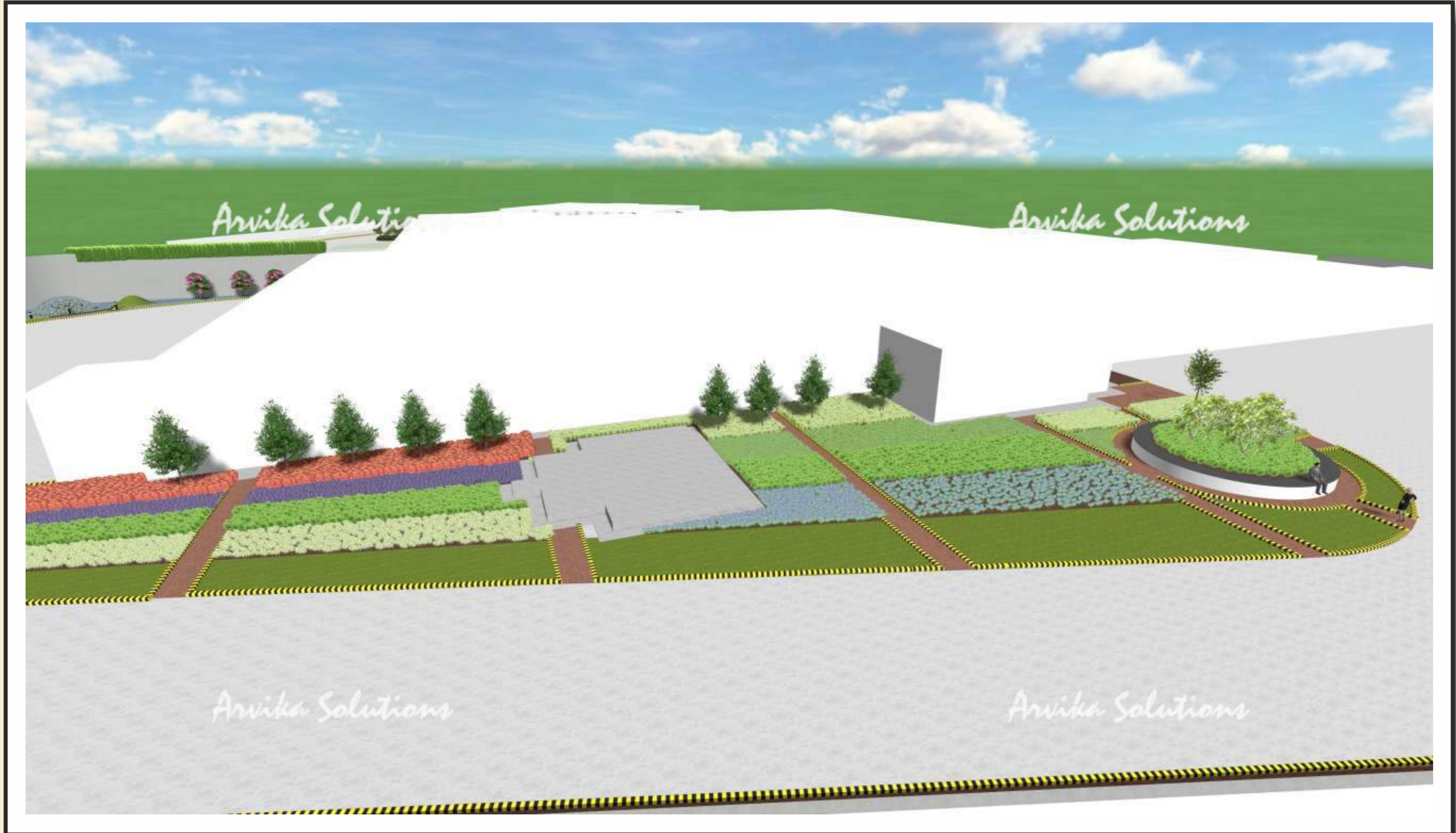

Rendered Views



Plantation Plan

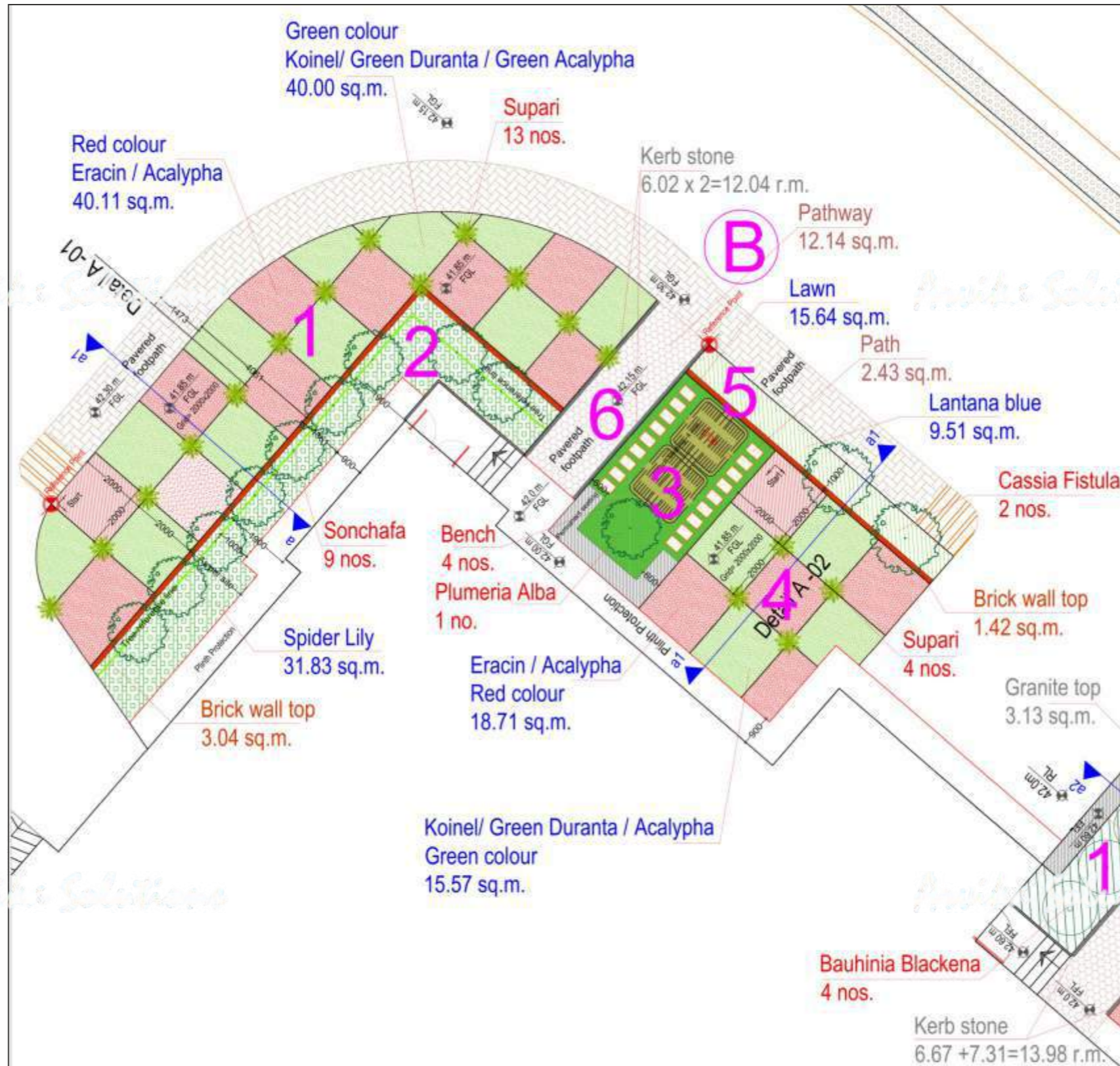

Rendered Views



Rendered Views



Presentation Plan - Terrace



Rendered Views of Landscape on Terrace



Rendered Views of Landscape on Terrace

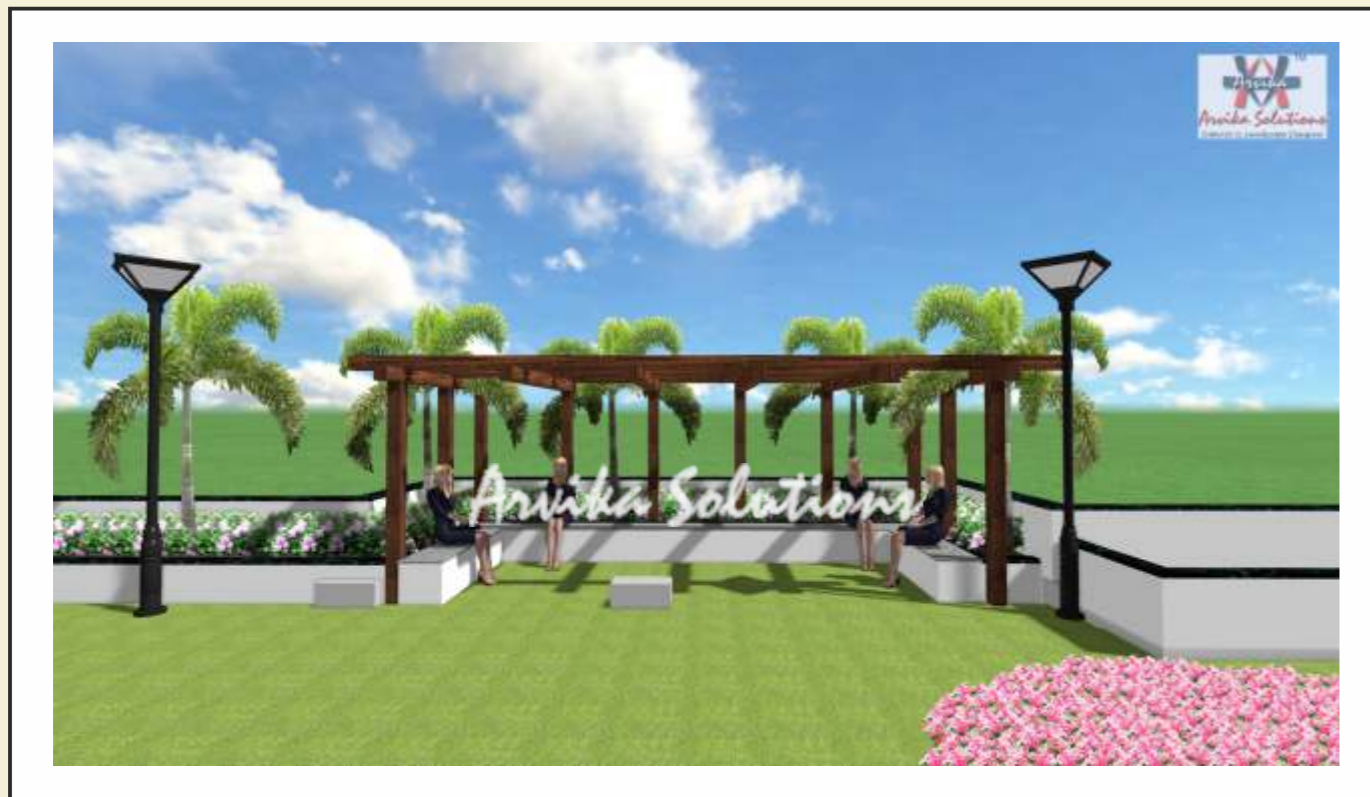

Material Pallette - Hard scape Materials



Stone -
Flame finish Atlantic black



Stone -
Colour Metal Chips

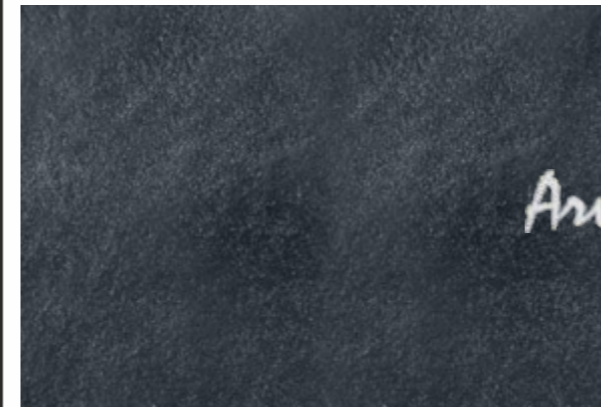

Stone -
Kadappa



Stone -
Sadarhalli Granite



Stone -
Shahabad



Stone -
Sandstone



Paving Block -
Water percolating



Sand Stone - Garden Benches

Material Palette - Illumination fittings

Bollards



K Lite -
Ritu Bollard -
6951, 6952, 6953, 6954



K Lite -
Sleek Bollard - Flat Top -
5744, 5747, 5753

Lamps



K Lite -
Dixon - 4990



Stome -
GL-9-LAMP
L:11" H:23" W:11" (Per No.)
TEAK STONE

Uplights



K Lite - Ciaz

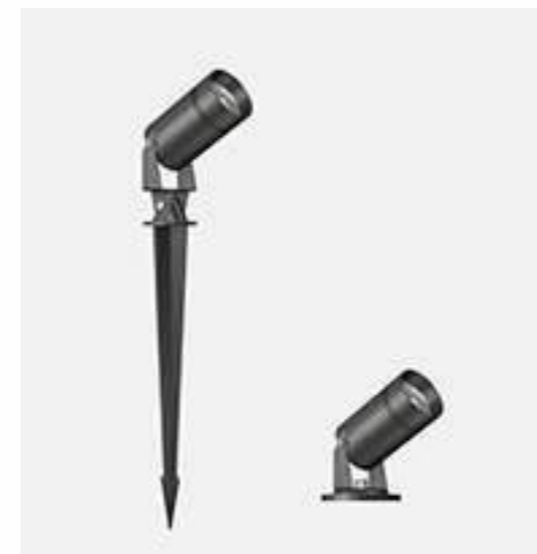

K Lite - Nebula Medi

Material Pallete - Shrubs, Ground covers & Hedge Plants



Acalypha Wilkesiana Java



Alternanthera Eracin



Bauhinia acuminata



chlorophytum Comsum



clerodendron inerme Koinel



Heliconia Yellow torch



Jatropha



Lantana Purple



Mondo Grass - Monrovia



Pandanus baptistii Vari.



Pogonatherum crinitum bamboo grass



setcreasea purpurea

Material Pallete - Trees



Alstonia Scholaris Satvin



Anthocephalus Kadamba



Bauhinia Blackenea Kanchan



Brassia



Cassia Fistula



Golden Bottle Brush



Jacaranda Mimosifolia



Millingtonia Hortensis



Spathodia



Tabebuia Rosea



Tabebuia



Thespesia Populnea

Material Pallette - Large Shrubs & Asthetic Plants



LS caesalpinia



LS Calliandra brevipes



LS Olenader Red



LS tecoma gaudi chaudi



LS Thevetia neriifolia



Sp. Pl. Areca Catechu Supari



Sp. Pl. Cycas



Sp. Pl. Ficus



Sp. Pl. Pisonia Alba



Sp. Pl. Plumaria Alba



Sp.Pl. Plumaria Pink Dwarf



Sp.Pl. Plumaria Pudica



Landscape Designing Hospitality Projects



A L D S

**ARVIKA LANDSCAPE DESIGNS
SOLUTIONS PVT. LTD.**

**An ISO 9000:2015
Certified Company**

This is a prestigious project of Welcome heritage group at famous Tiger reservoir Tadoba in Chandrapur District Maharashtra. Its is adjacent to water reservoir where siting of Tigers is highly possible.

The project is beautifully designed by Ar. Ashfaque Ahmed (Nagpur Maharashtra). He has put forth his experience in designing the project. The challenge in designing is the climactic conditions in Tadoba. Temperature reaches 47 degree Celsius in peak summer. Major amenity areas are open & no air conditioning was done to give rustic but classic feel of the resort.

Our role was to make the area completely green with aspect of minimum water requirement for landscape area. We have incorporated large size trees which gives shade and again has to be native to enure wild life presence in resort & needs lesser water. We have used shrubs which attracts butterflies & birds. To enhance mood of guests colour ful & fragrant flowering plants were used which can be utilised at Spa and flower decorations. Fruit trees & vegetable gardens are designed to provide guest best quality fruits & food. Large royal palm trees are designed to give feel of tropical & rural areas which are ideal for any resort.

Water body is created to give Live water element. Lotus pond is designed on either sides of entrance to reception to give feel of rural areas. Grill restaurant which is air condition free and is completely open area, is surrounded by water trench which has fish & is beautifully lite to give special mood in evening times.

Lastly each cottage has its own garden in the back yard to enjoy the resort fullest.

Site Details

Client : Vanyavillas Resort (Welcome Heritage Group)

Site : Tadoba, Dist. Chandrapur Maharashtra.

Space under scope of work : Resort

Area under scope of work : 33000 sqm

Scope of work : Designing of Soft scape, Water body, Hardscape & Irrigation system & Plants supply

Duration : Sep 2016 to Sep 2019



A L D S

ARVIKA LANDSCAPE DESIGNS
SOLUTIONS PVT. LTD.

An ISO 9000:2015
Certified Company

Landscape Presentation Plan



Trees Plantation Plan



Irrigation System Plan



Rendered View



Rendered View



Rendered View



Rendered View



Rendered View



Working drawings for Water body

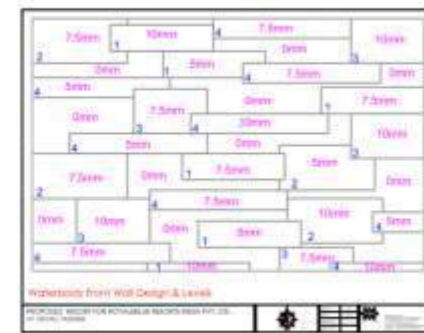
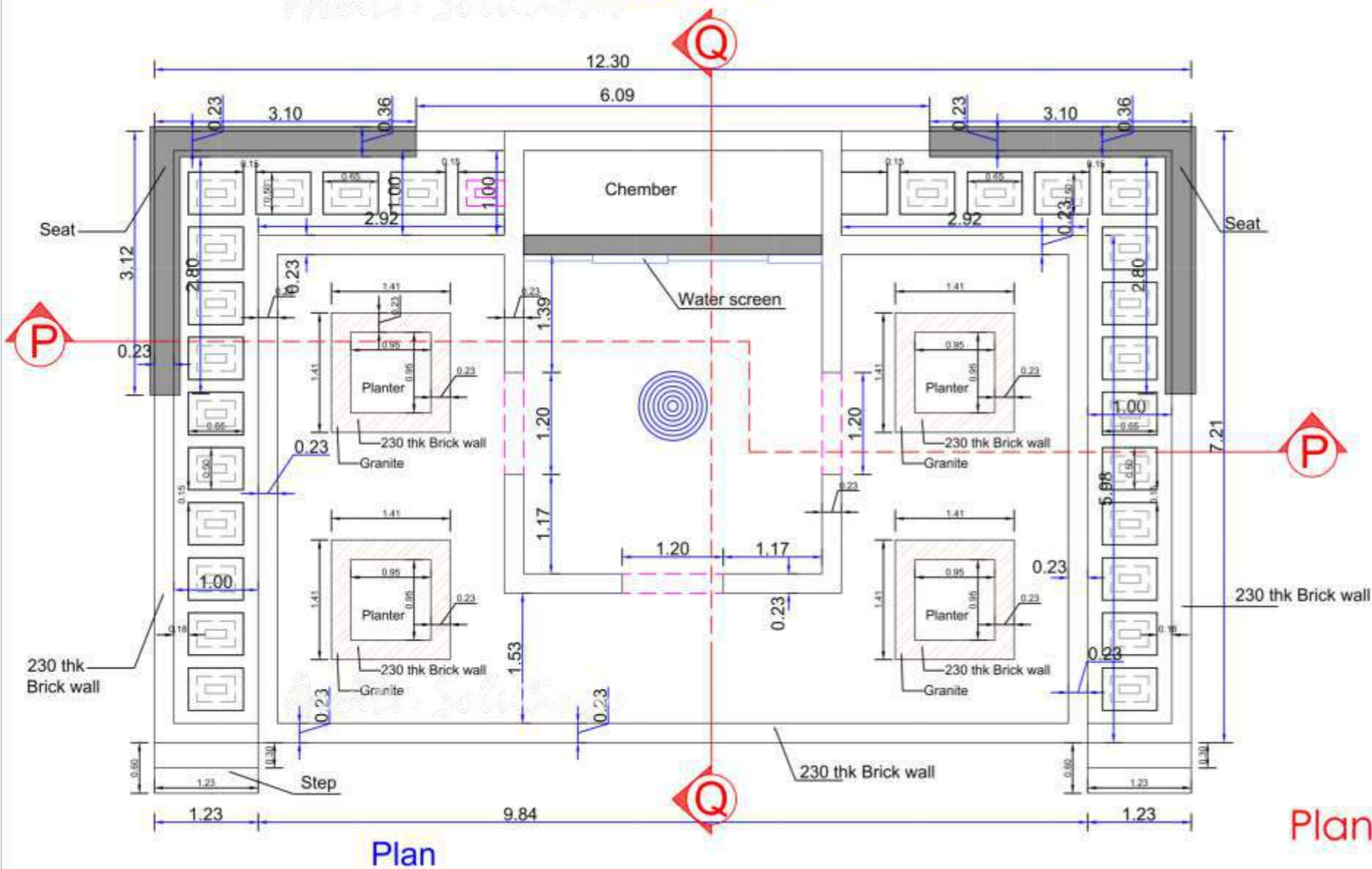
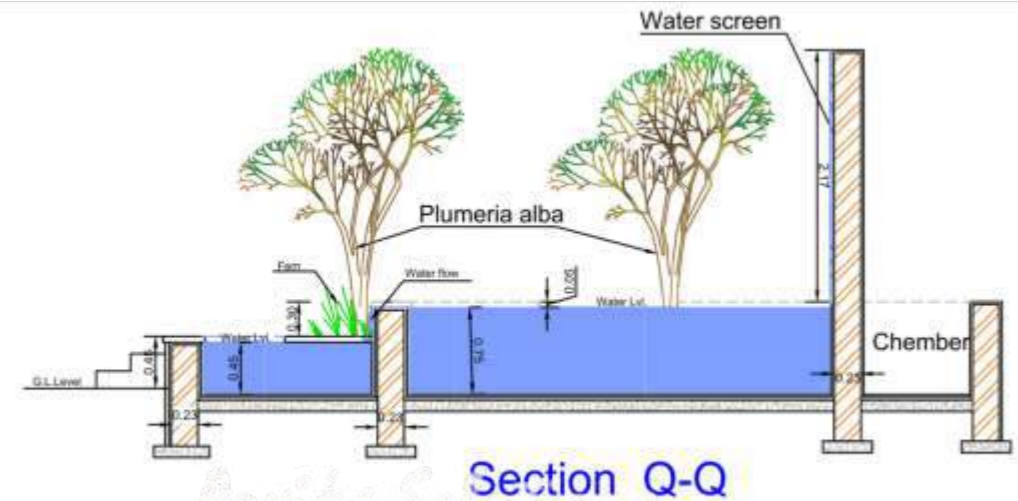
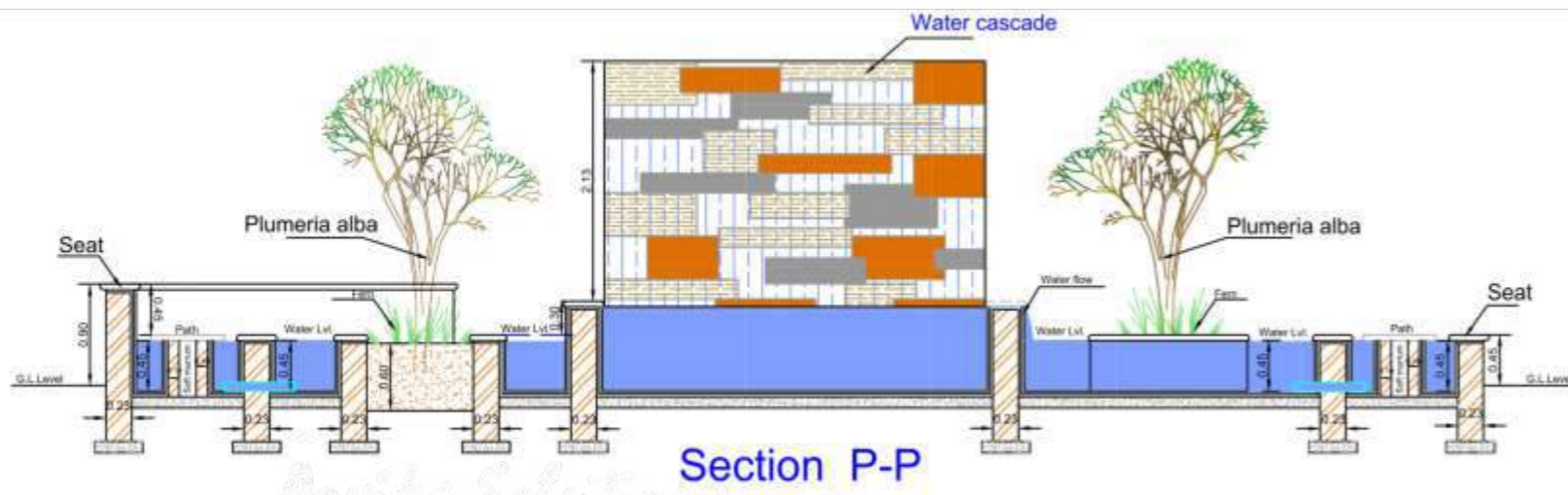

Plan for Water body Lineout & Details

Rendered view of Water body



Working drawings of Grill Restaurant

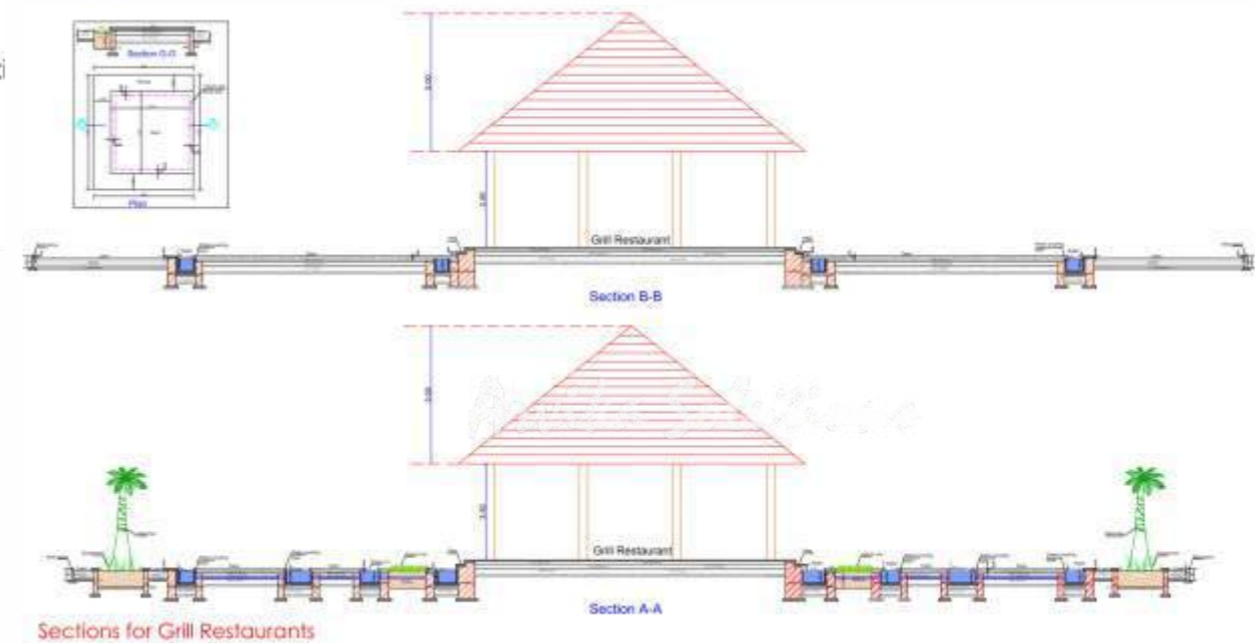
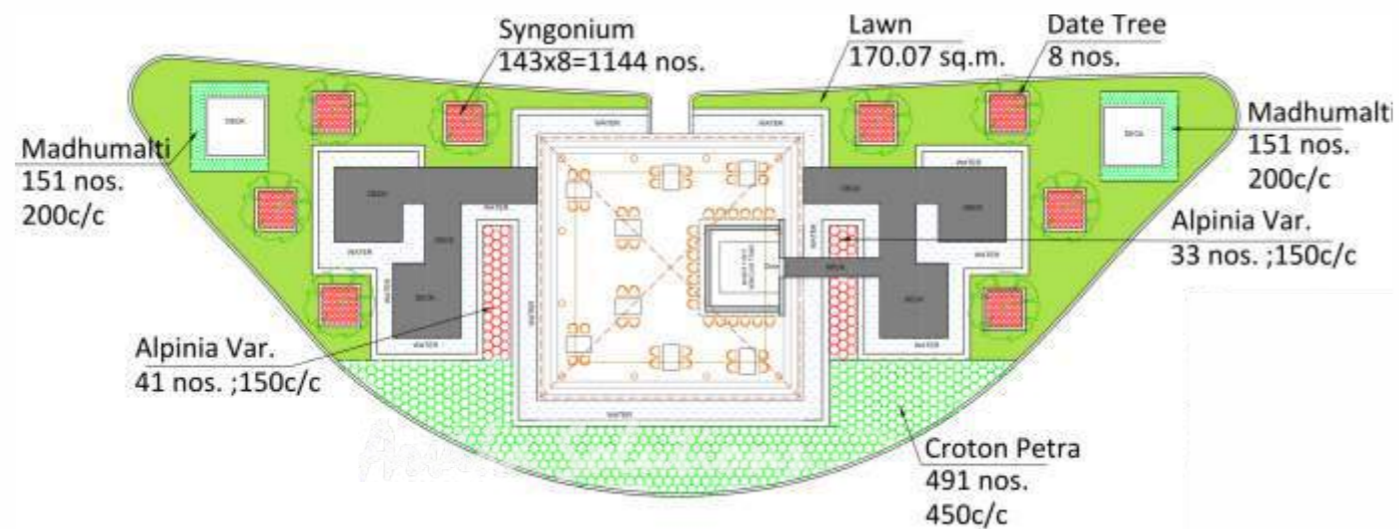
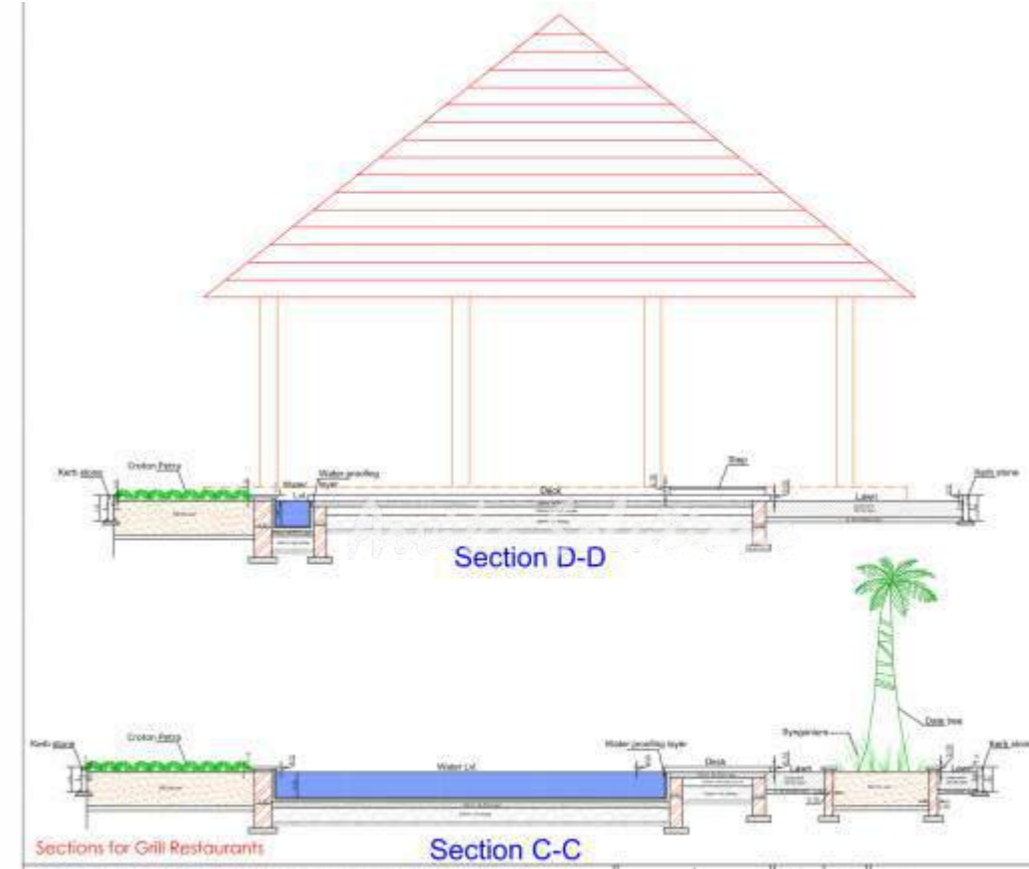
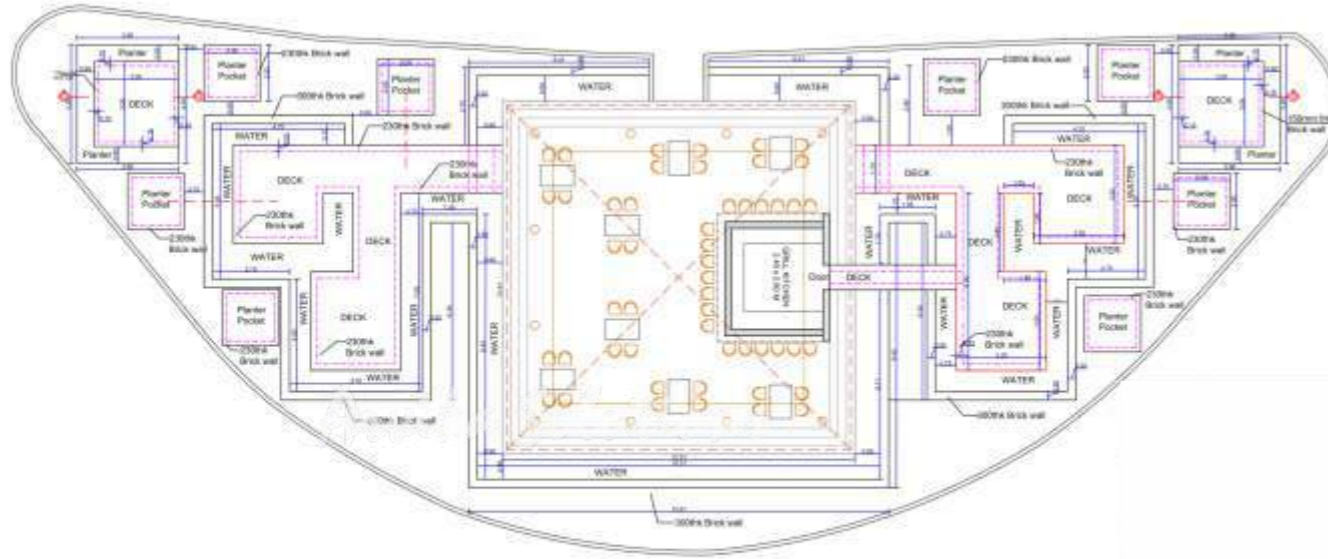

Rendered view of seating area opp reception



Rendered view of seating area opp reception

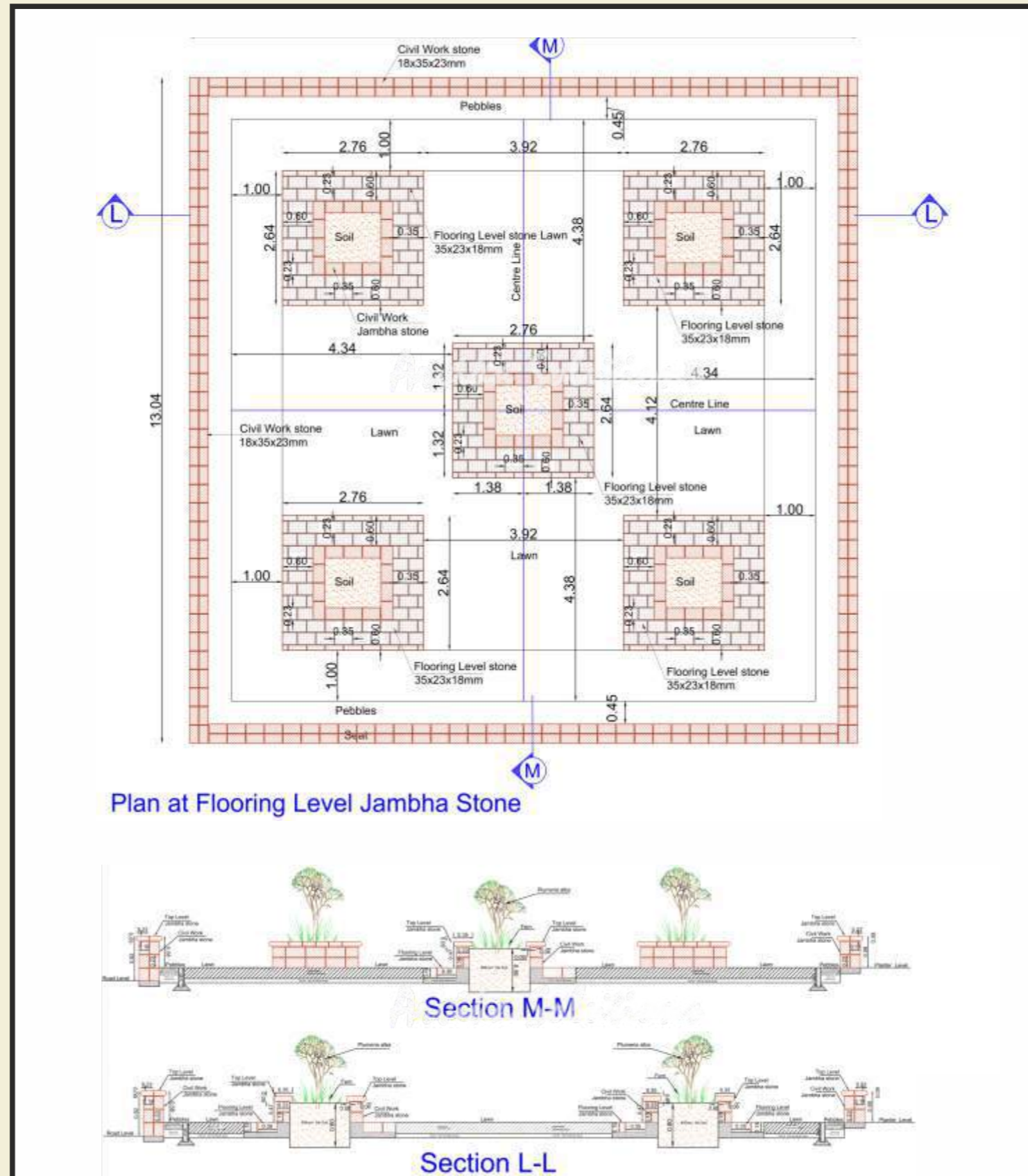

Rendered view of seating area opp reception



Arvika Solutions



Site Photographs



Site Photographs



Site Photographs



Site Photographs



Site Photographs



Site Photographs





Landscape Designing Public Spaces



A L D S

**ARVIKA LANDSCAPE DESIGNS
SOLUTIONS PVT. LTD.**

**An ISO 9000:2015
Certified Company**



Site Details

Client : Pune Munciple Corporation. (Garden Department)

Space under scope of work : Public Garden

Area under scope of work : 20,000 sqm

Scope of work : Landscape Designing, Soft scape, Civil Works, Water body, Children Play area & Irrigation system

Duration : June 2013



A L D S

**ARVIKA LANDSCAPE DESIGNS
SOLUTIONS PVT. LTD.**

**An ISO 9000:2015
Certified Company**

Master Plan

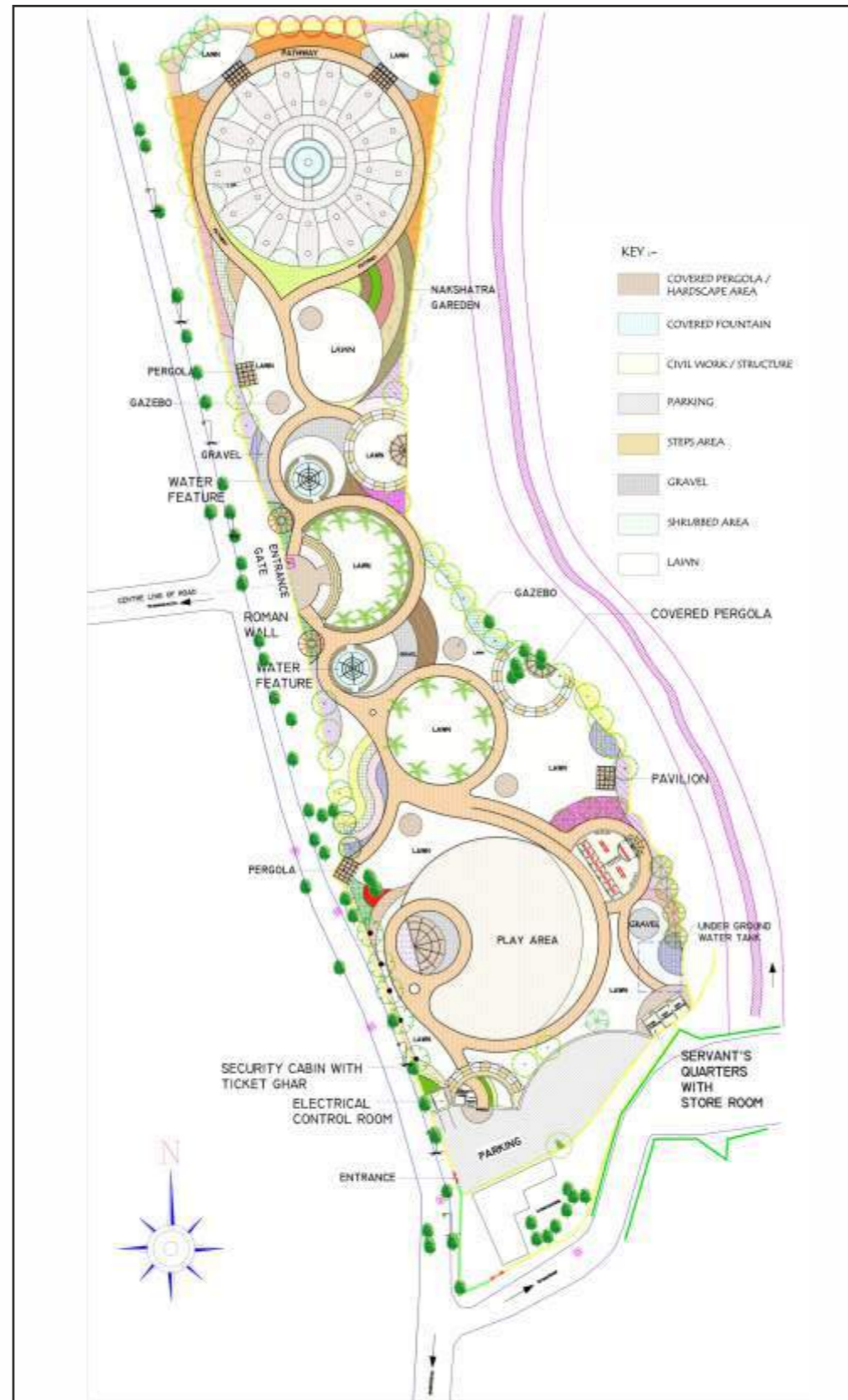

Level Plan

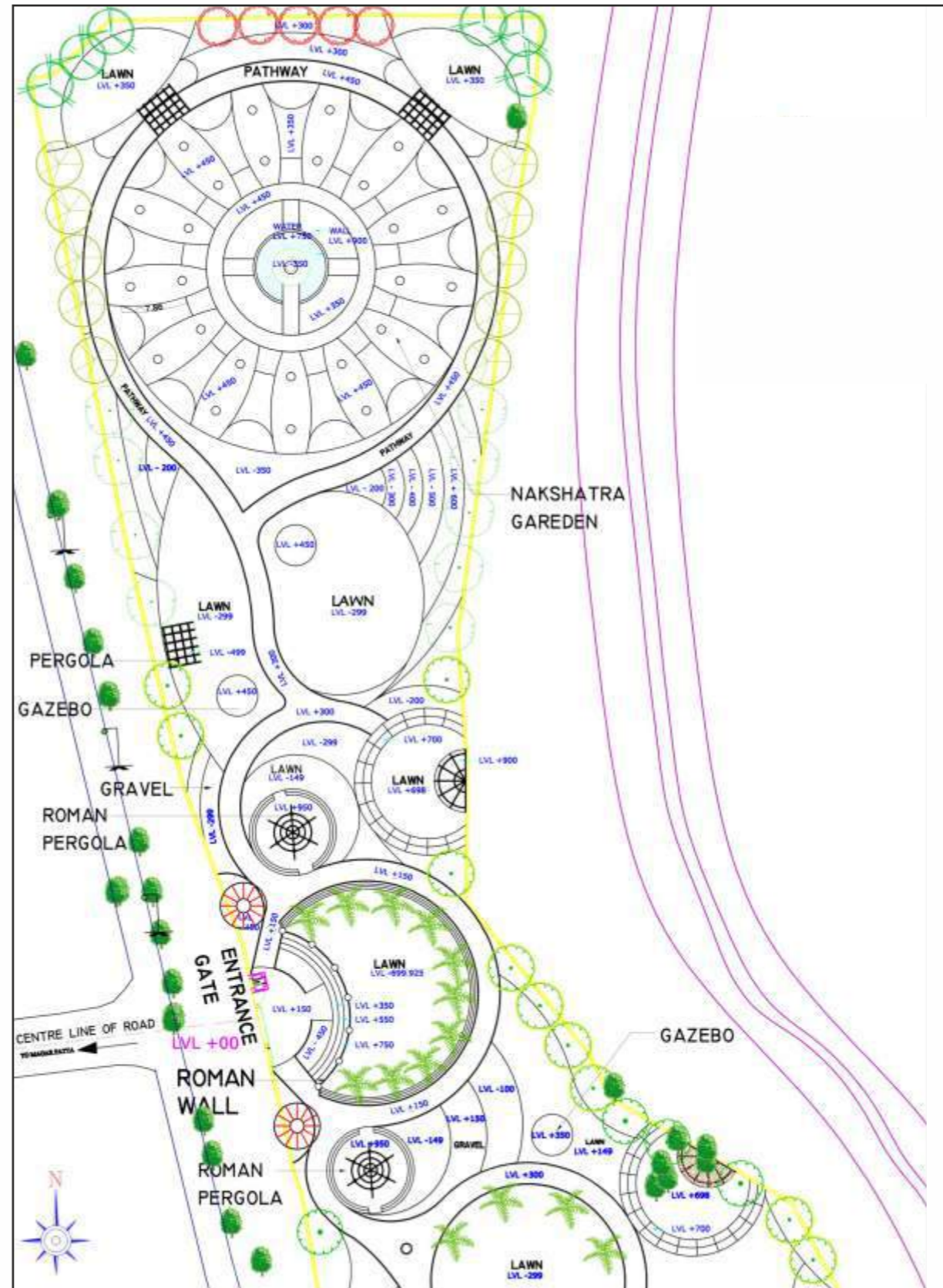

Working Drawings For Boundary Wall & Gate

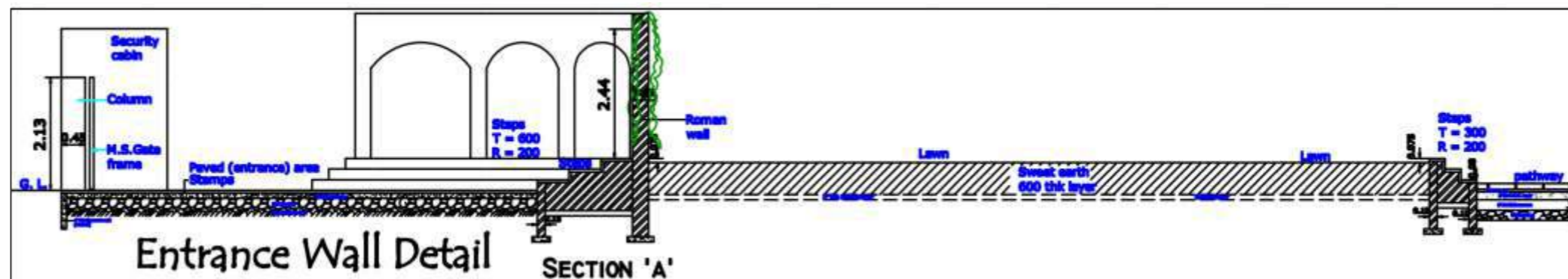
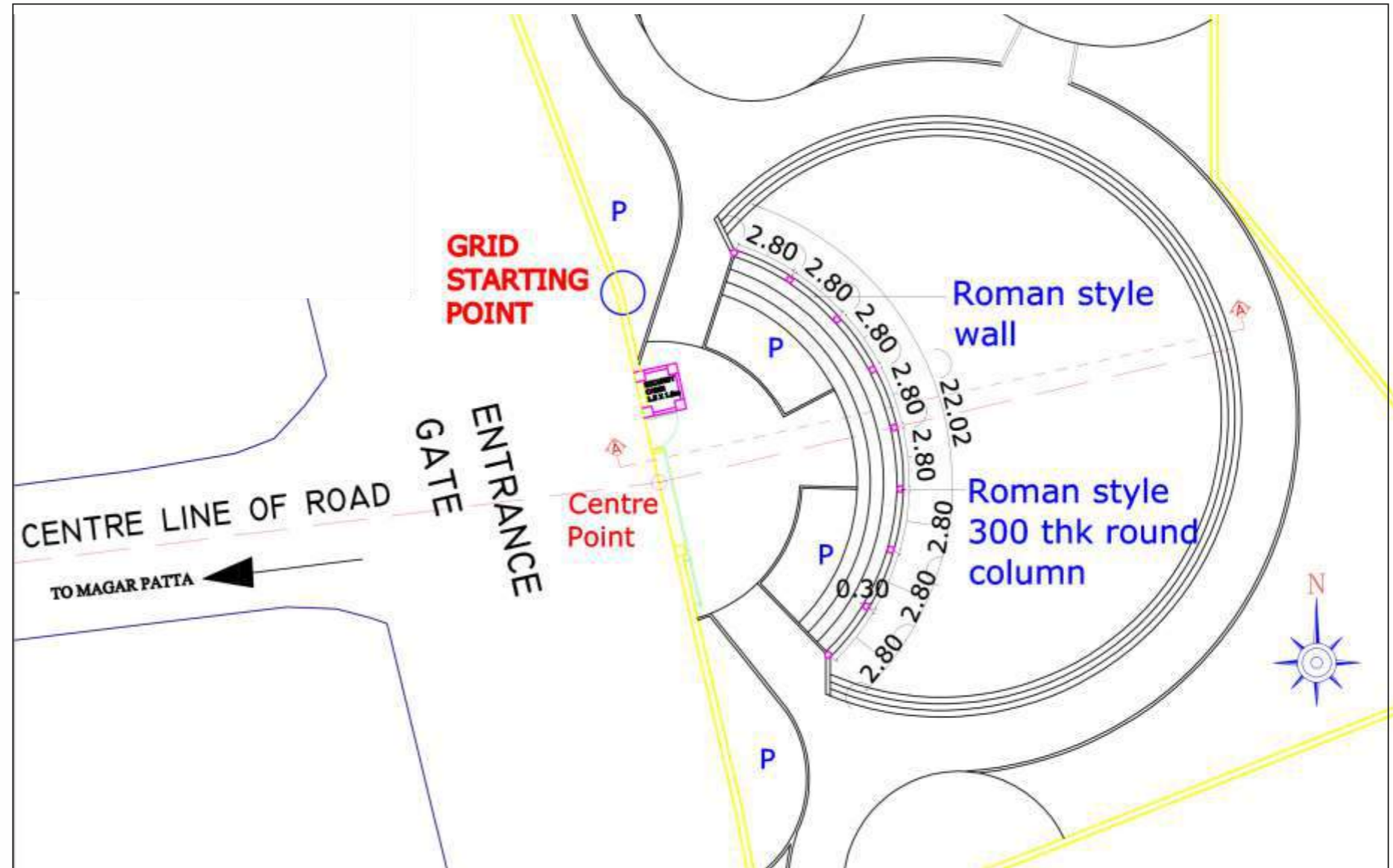
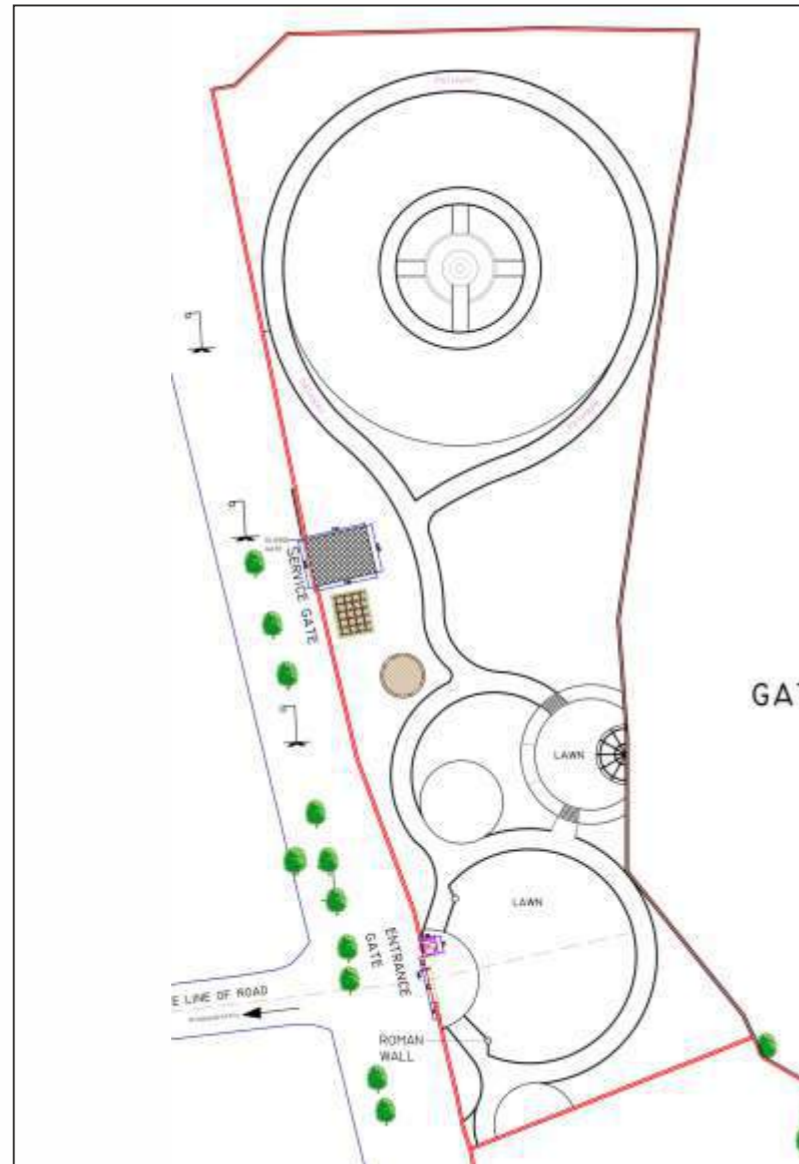

Working Drawings For Boundary Wall & Gate

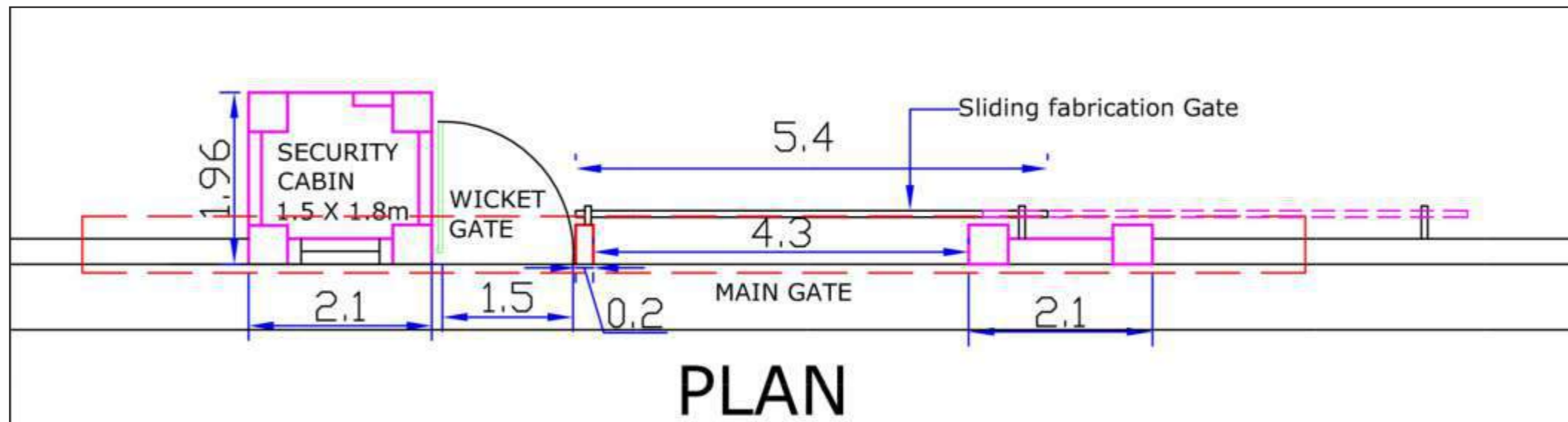
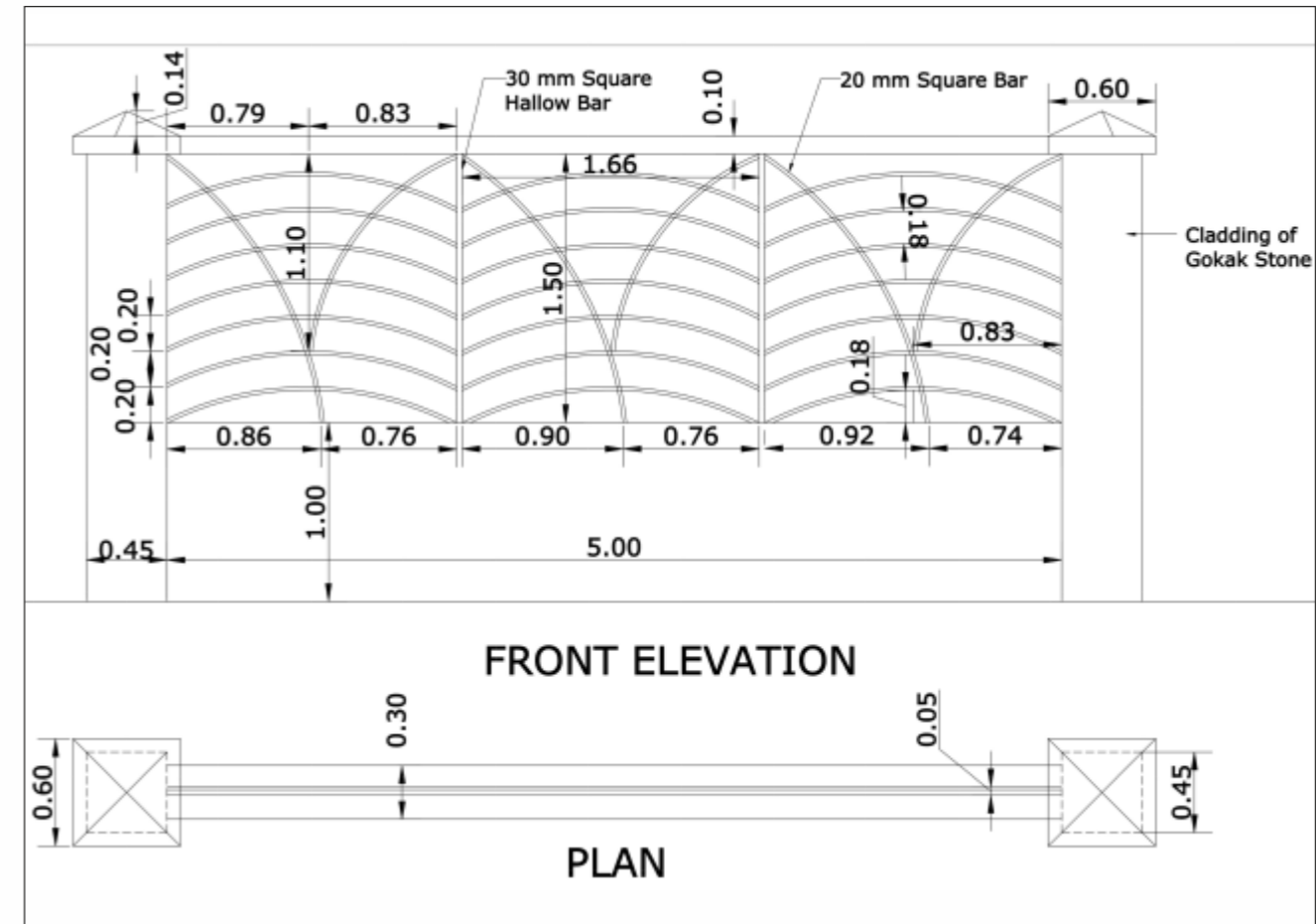
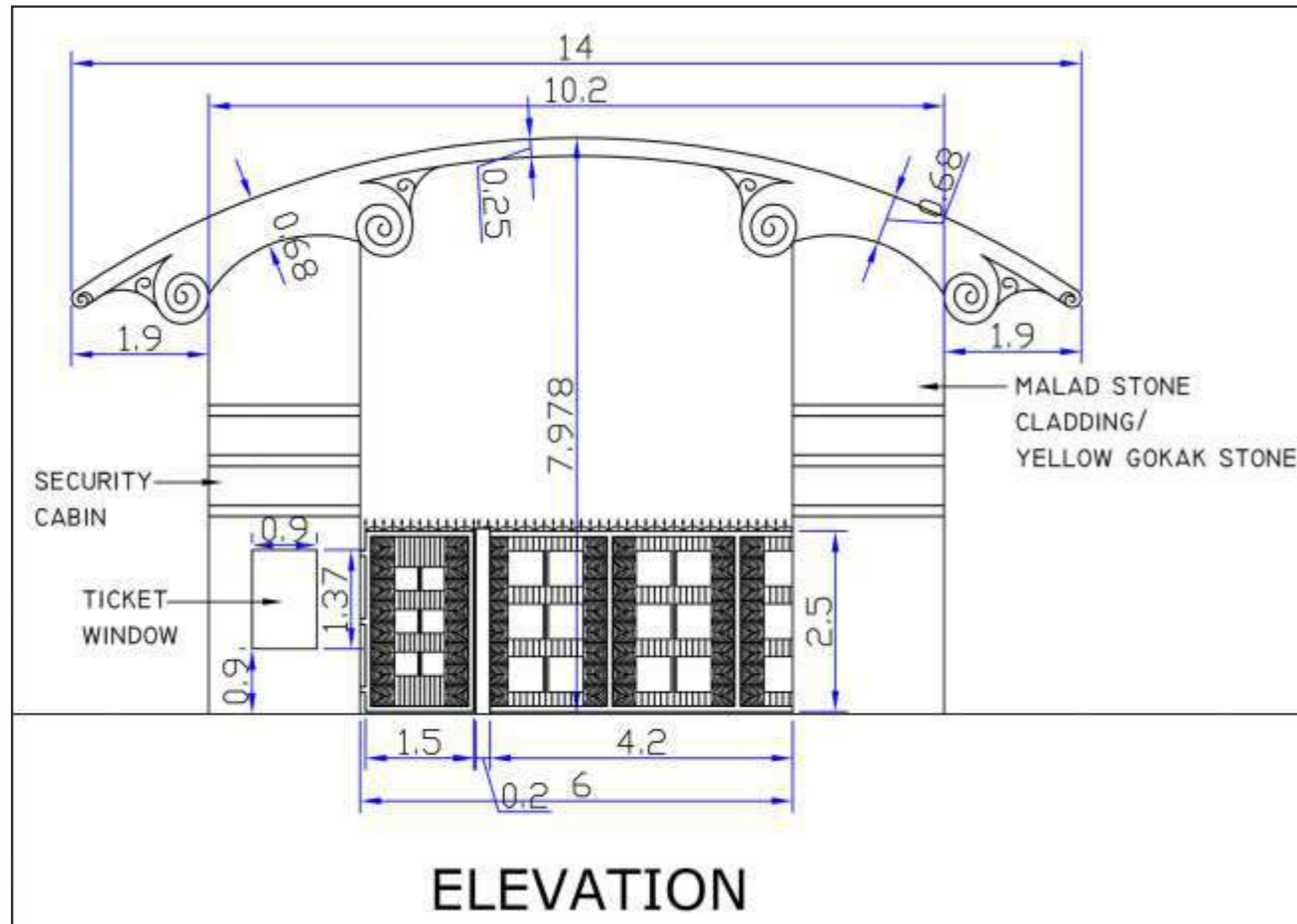

Working Drawings For Security Cabins, Toilets & Servant's Quarter

Security Cabin

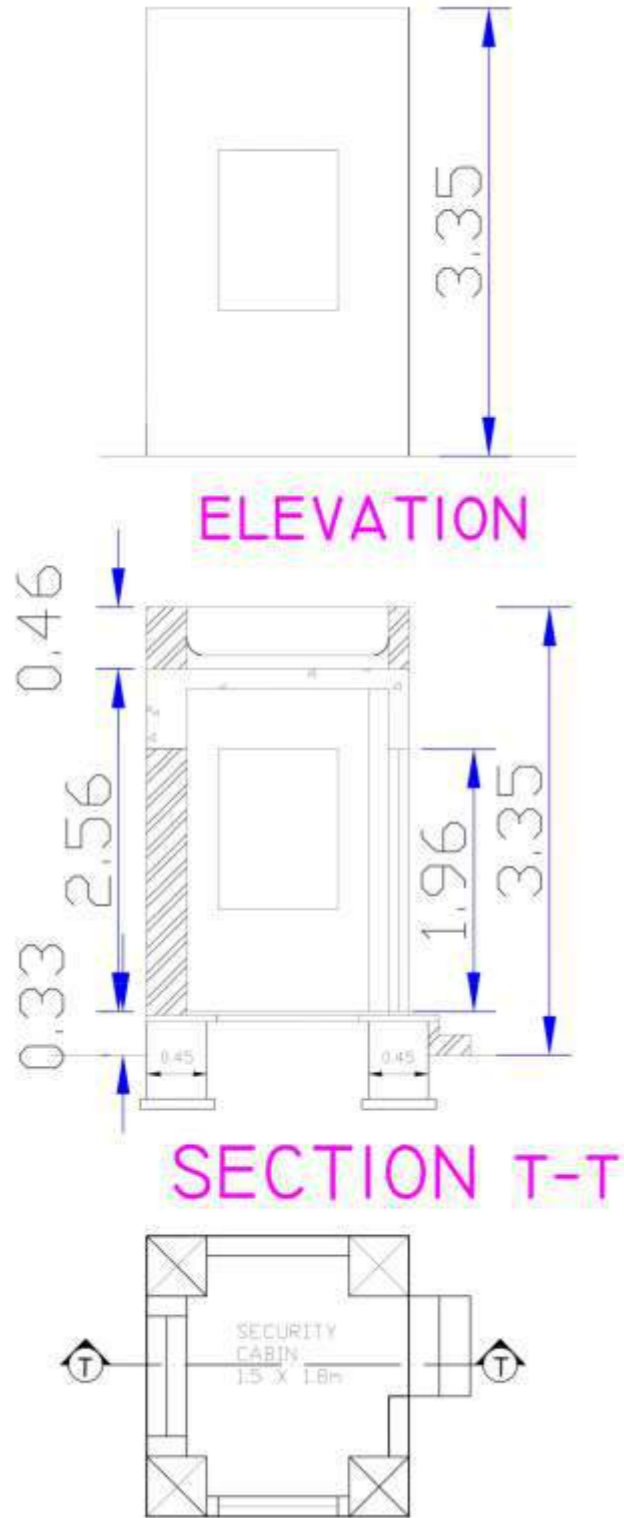

Toilet Block

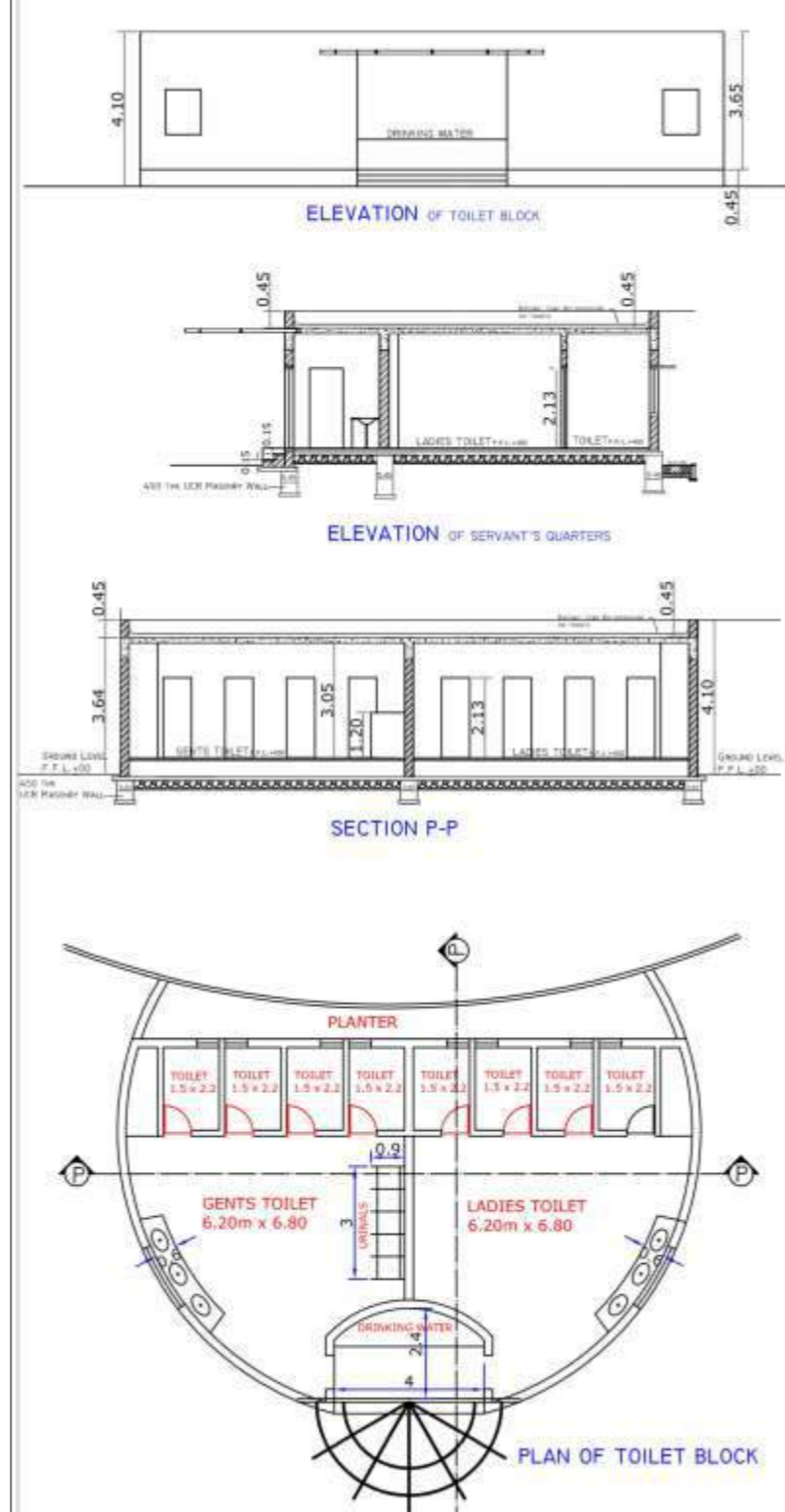

Servant's Quarters

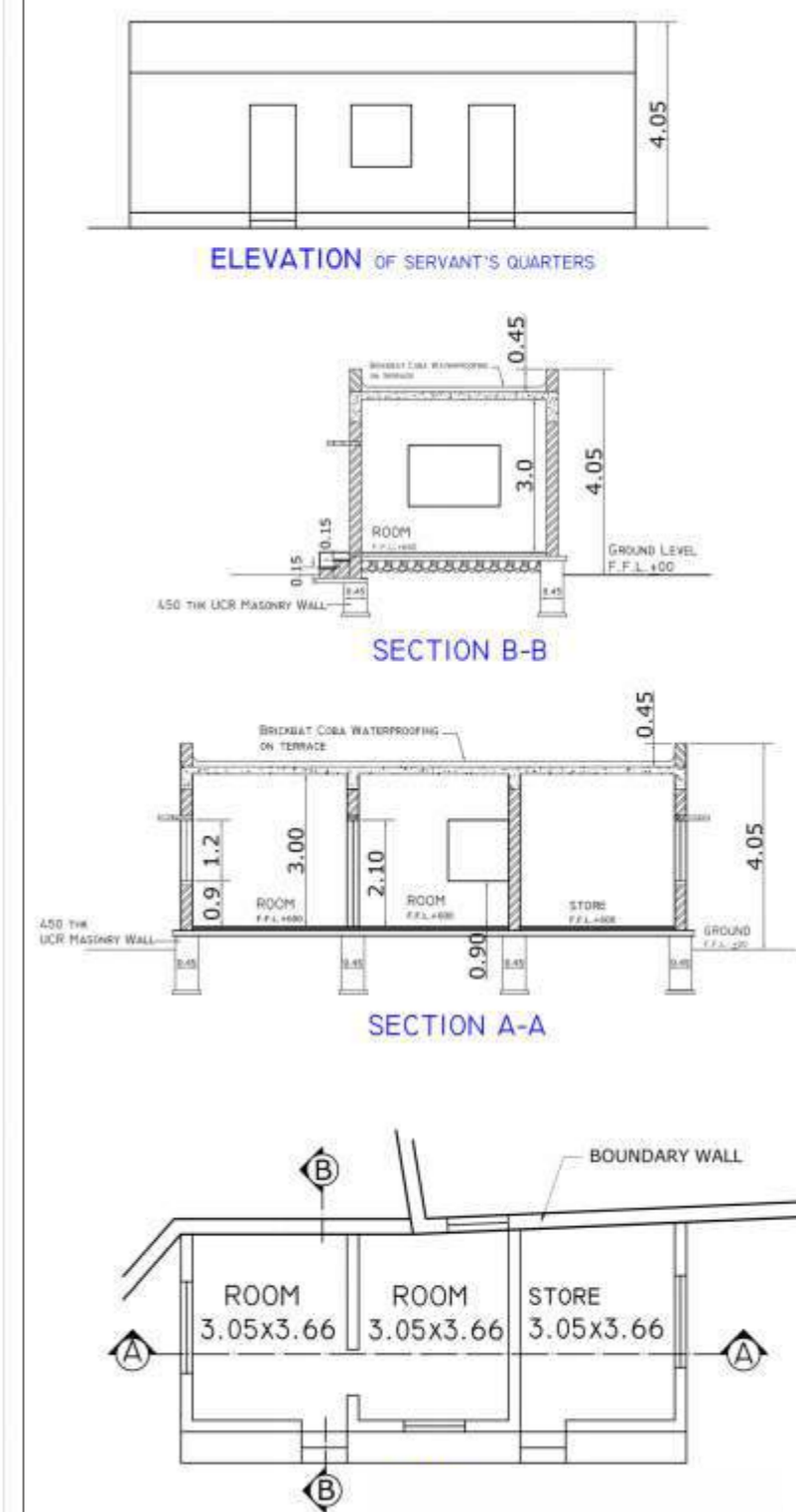

Working Drawings For Water Body

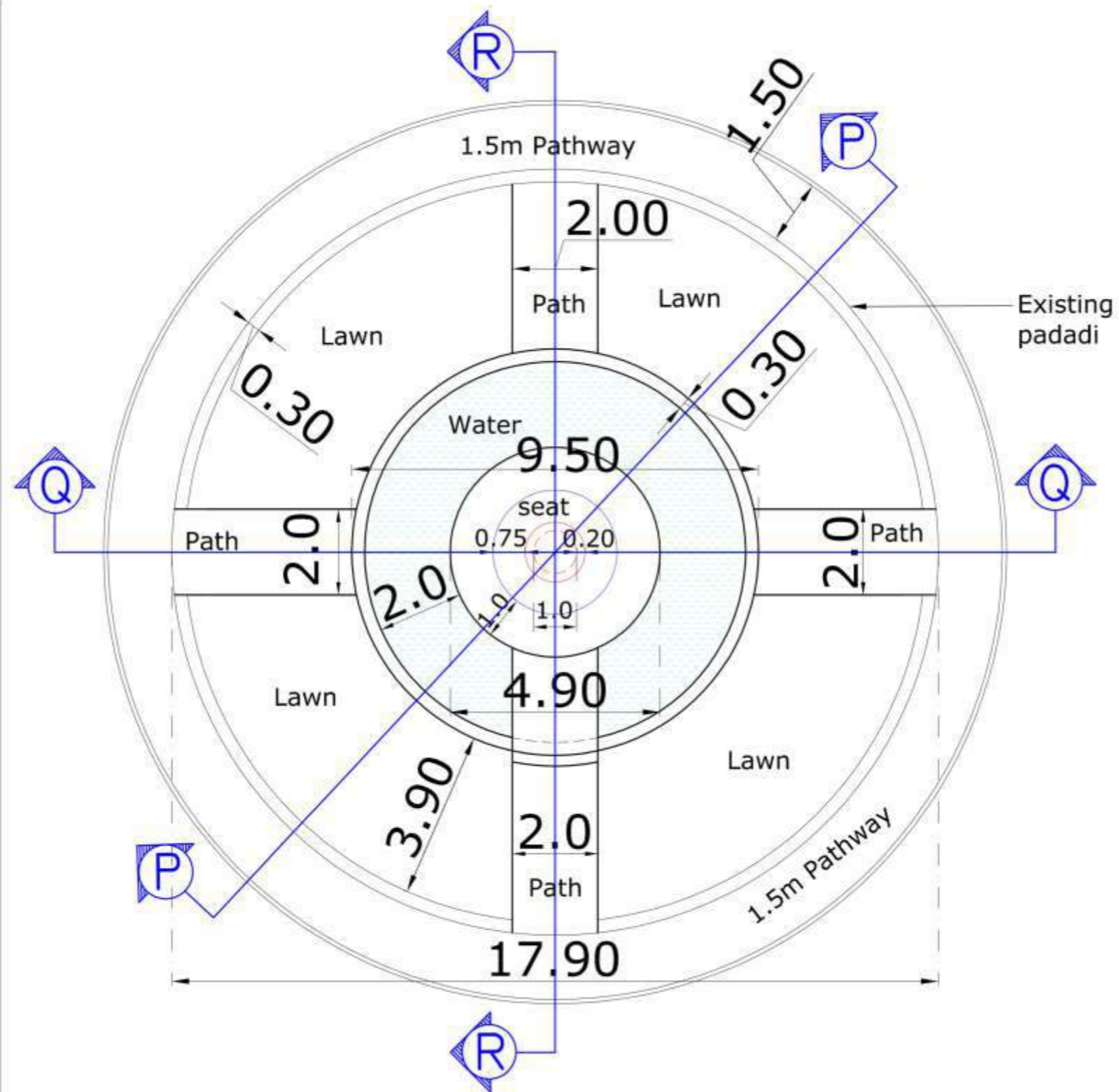

Working Drawings For Water Body

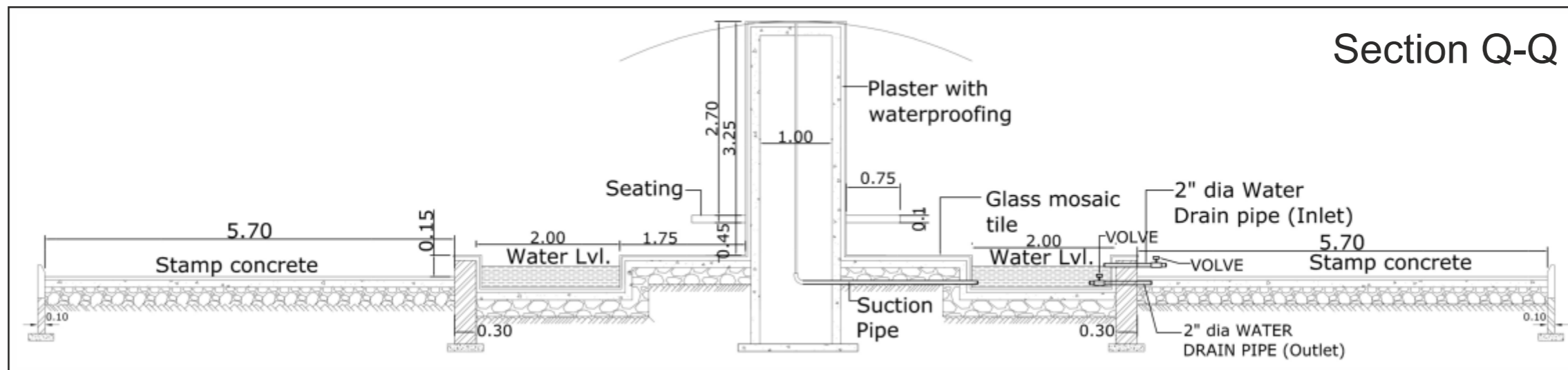
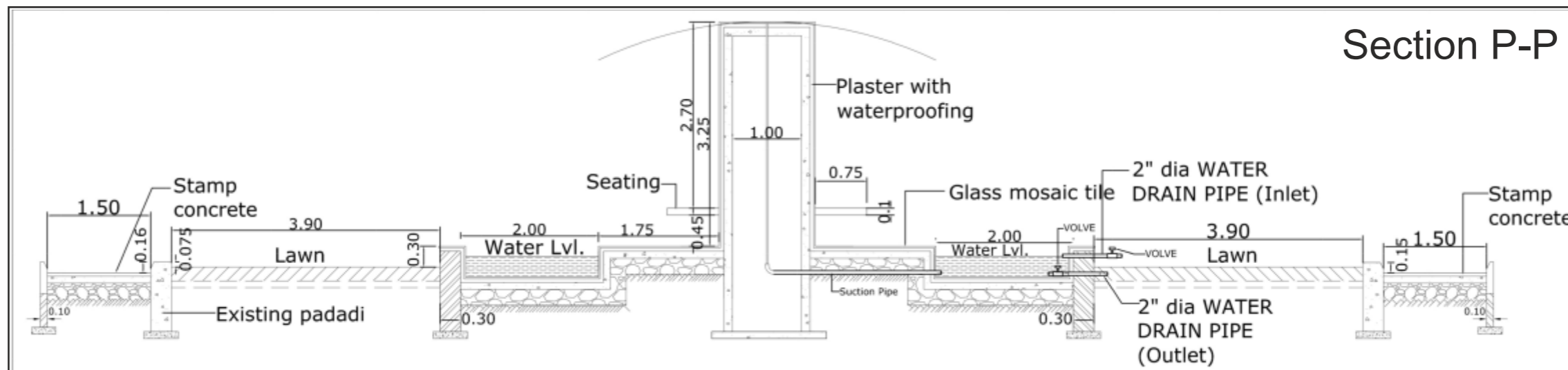
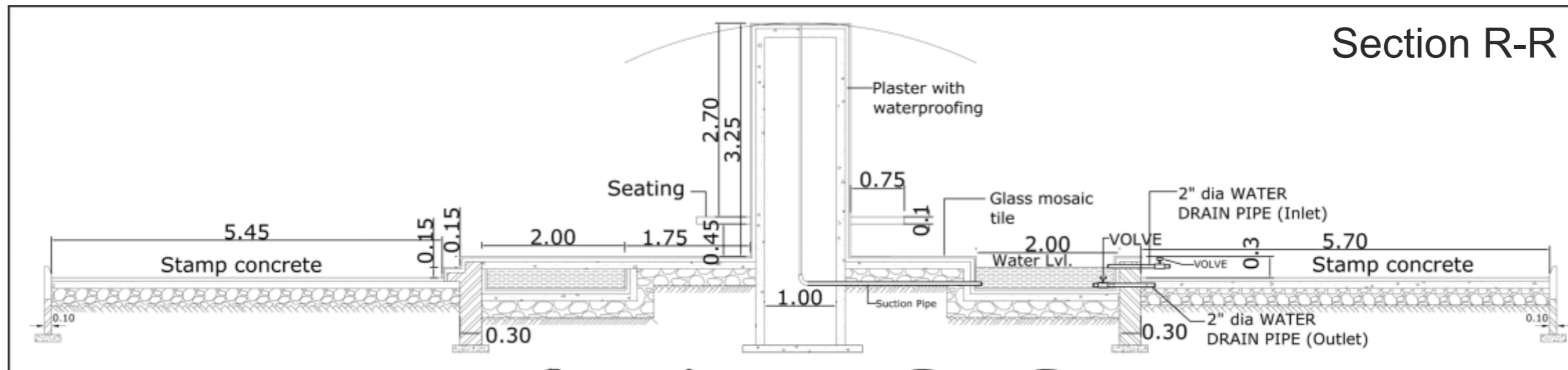

Working Drawings Roman Pergola & Roman Wall

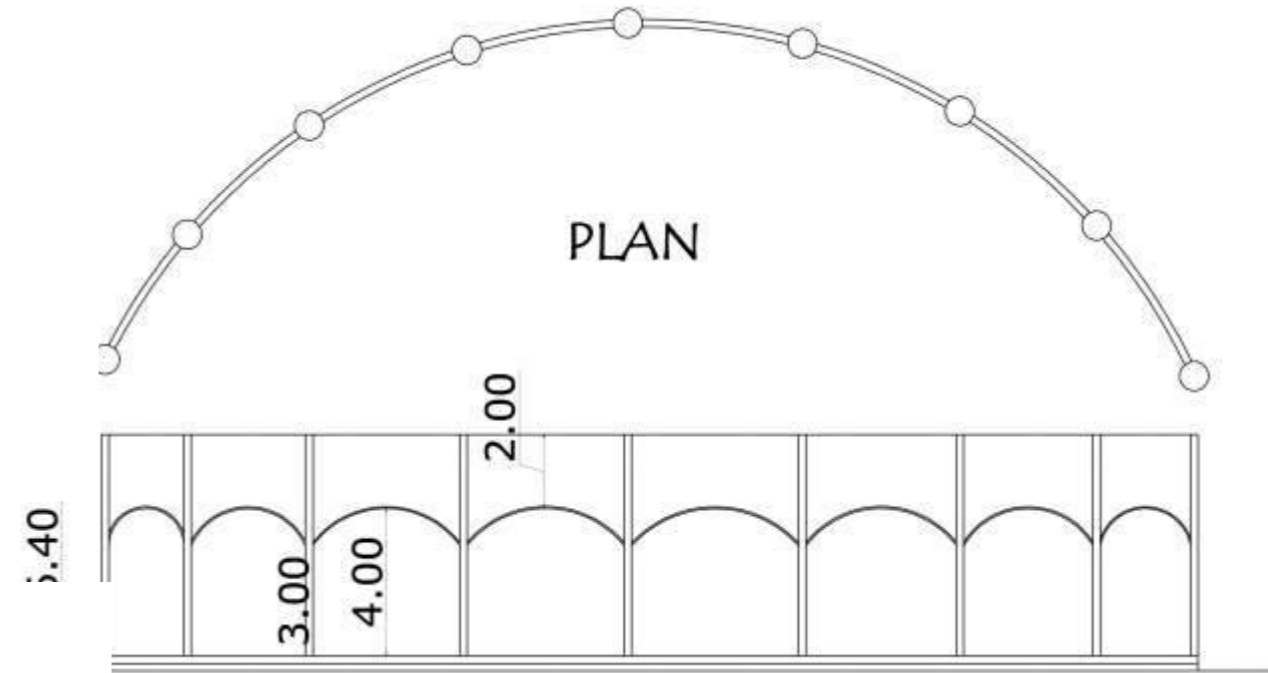
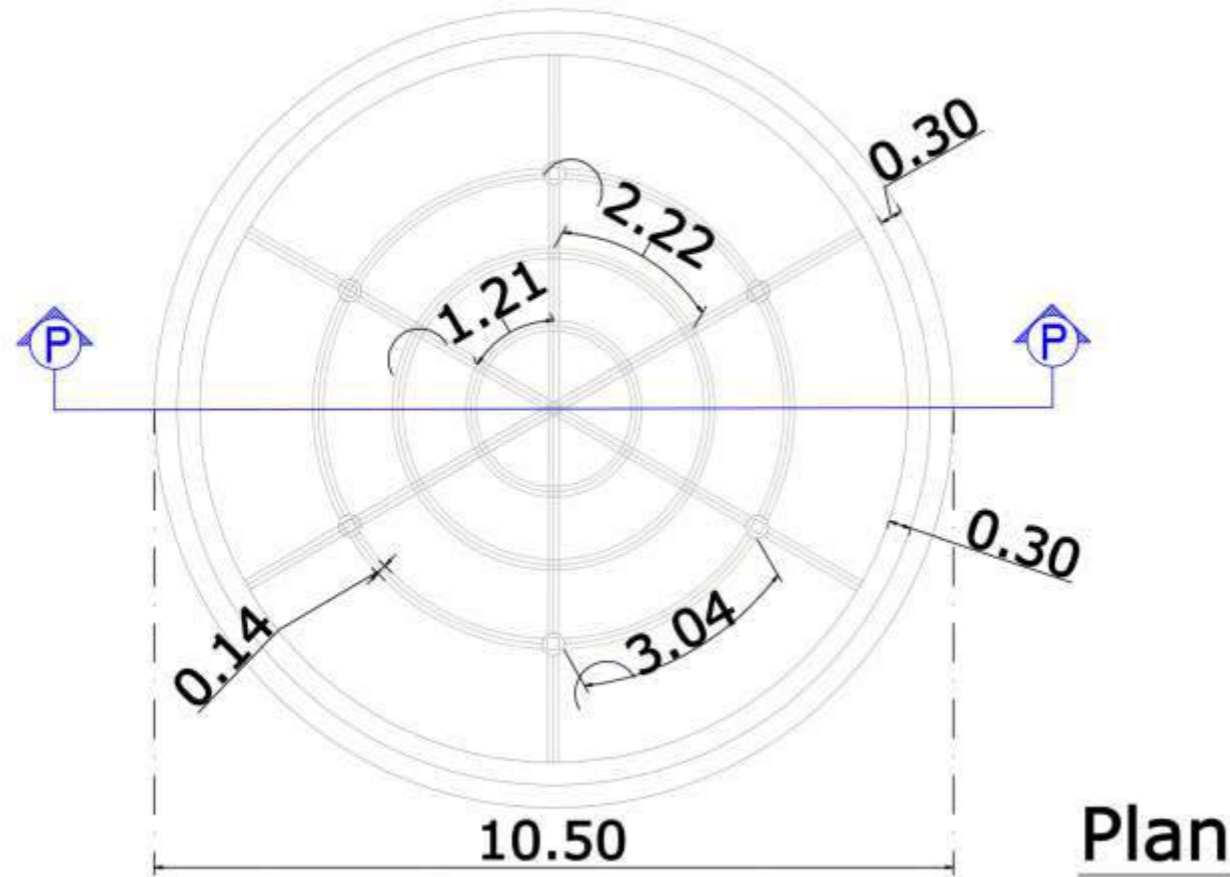

Steps
T = 350
R = 200

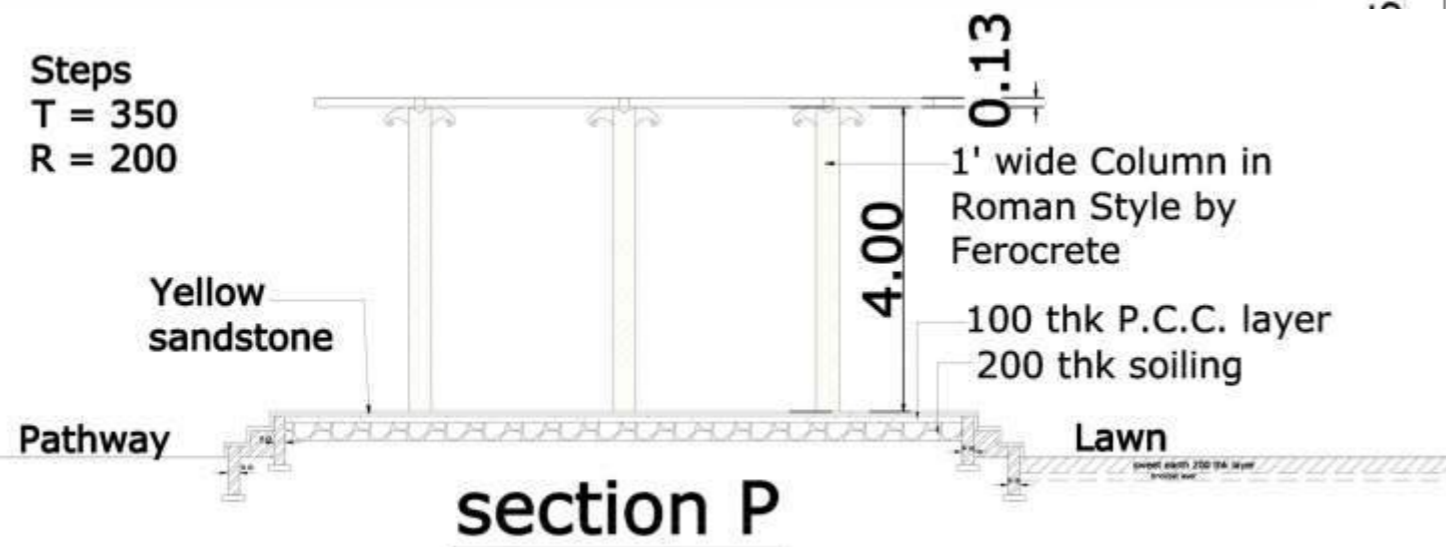

Working Drawings Gazebo

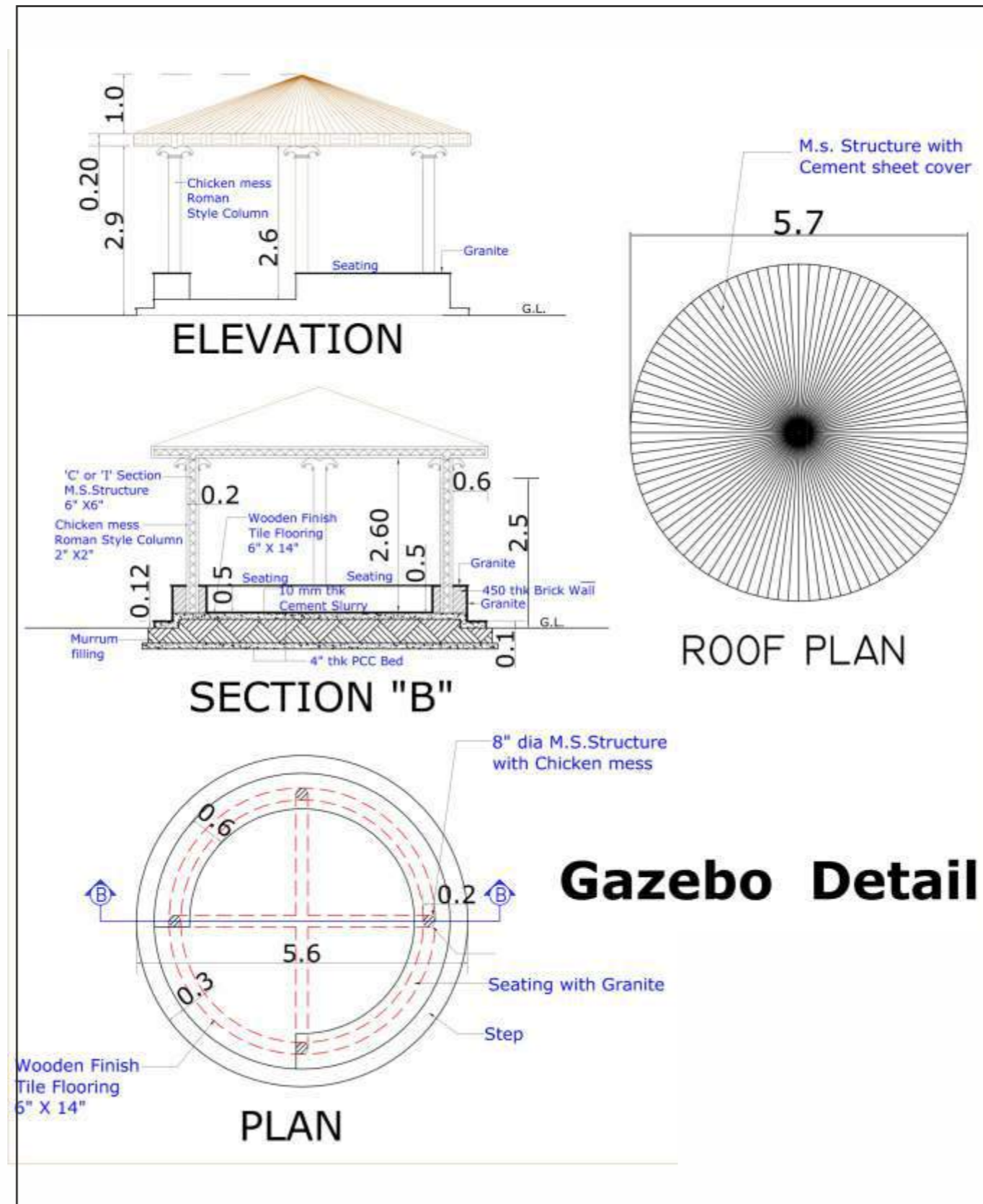

Working Drawings For 1st Phase Landscape Line Out

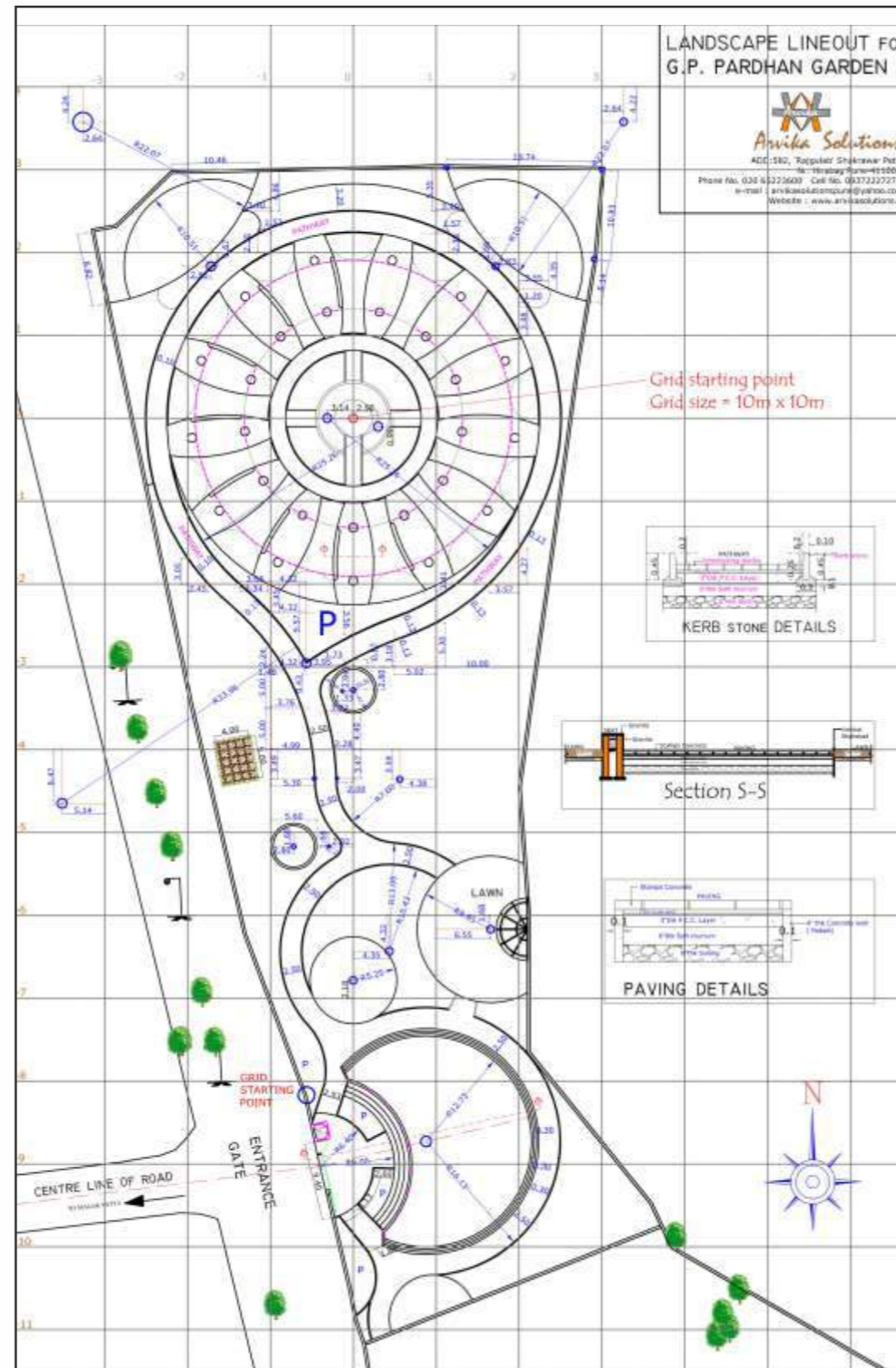

Working Drawings For 1st Phase Trees Plantation

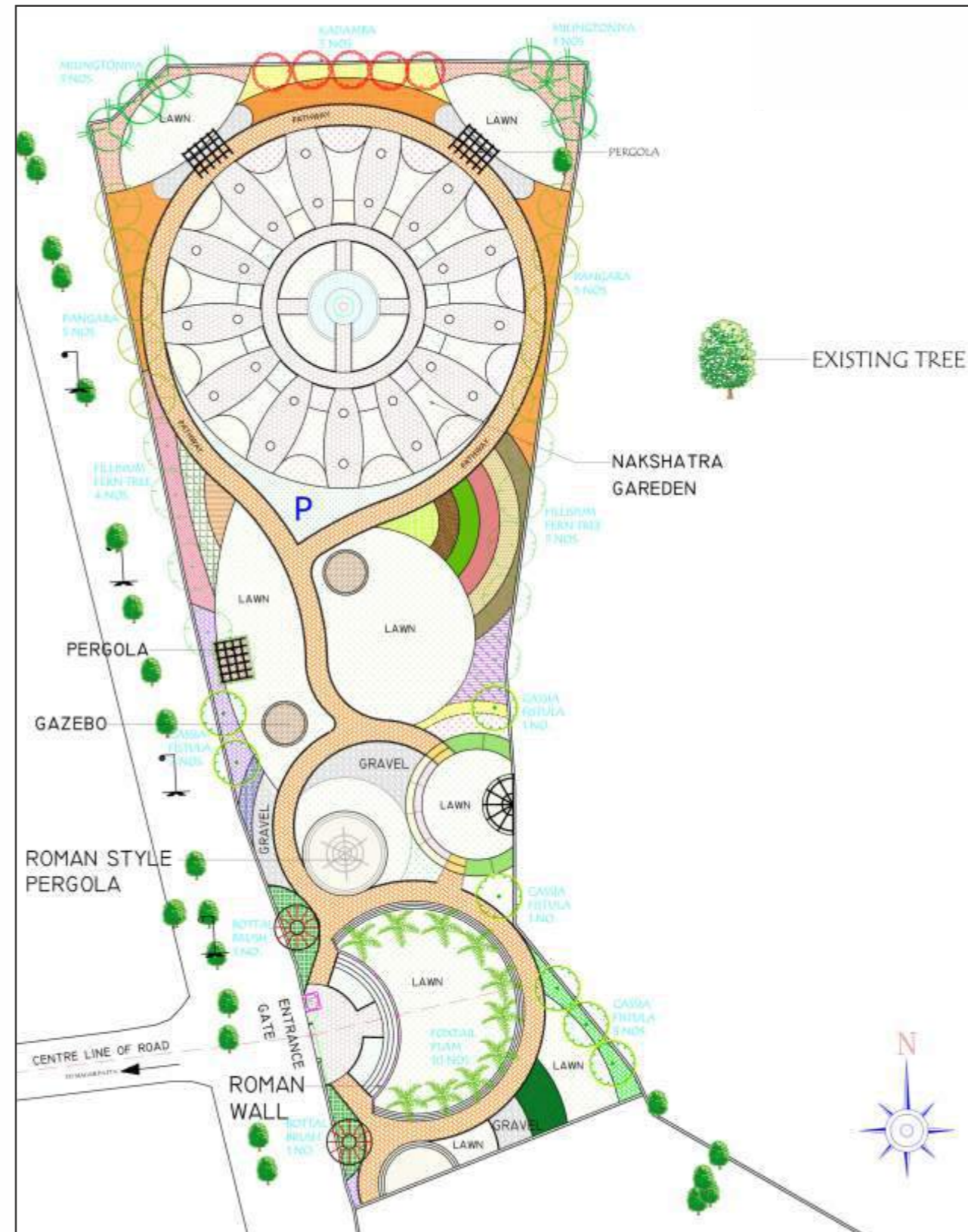

Working Drawings For 1st Phase Lawn Plantation



Section S-S



Working Drawings For 1st Phase Shrubs Plantation

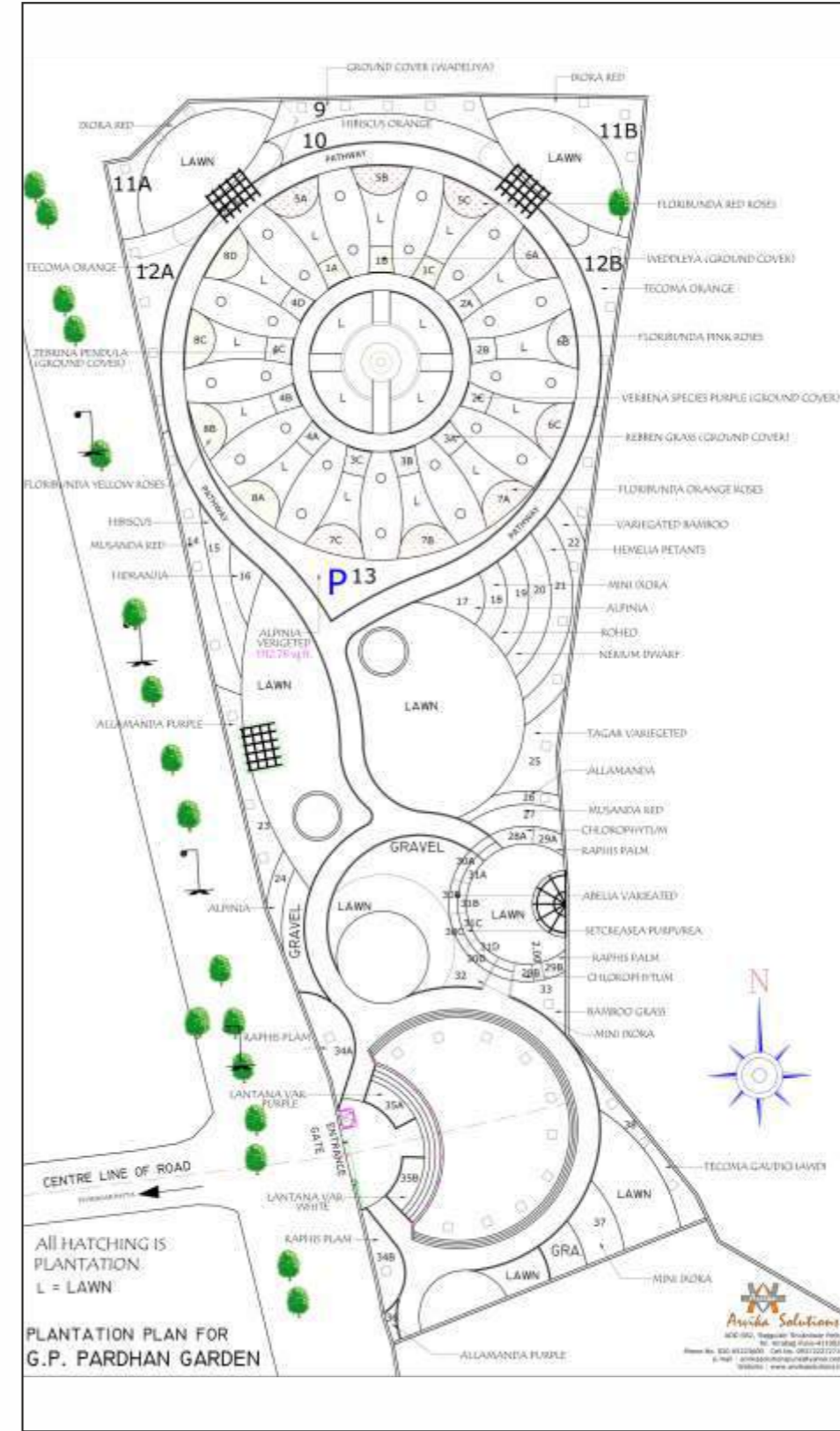
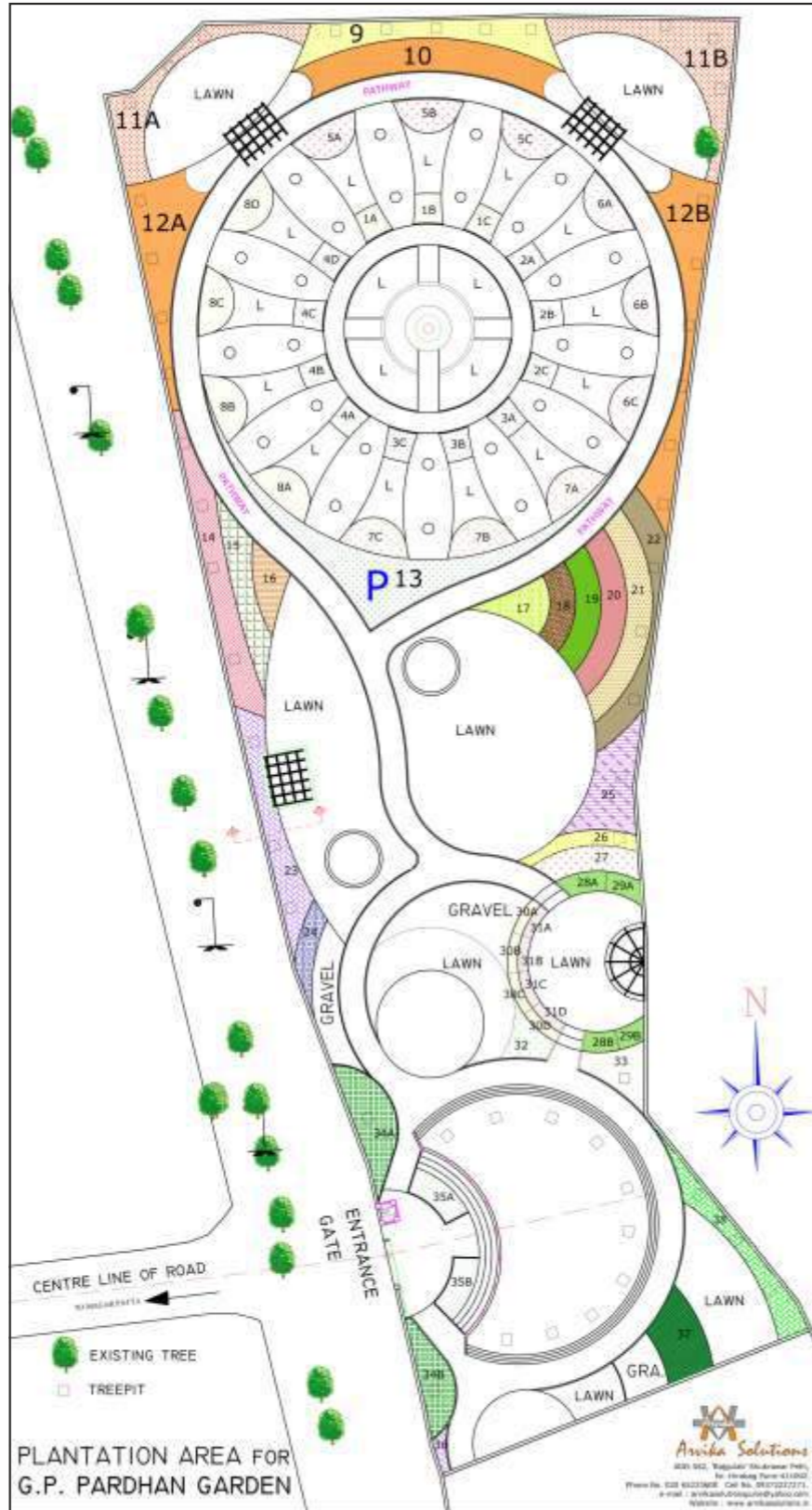

Working Drawings For 1st Phase Gravel Spreading

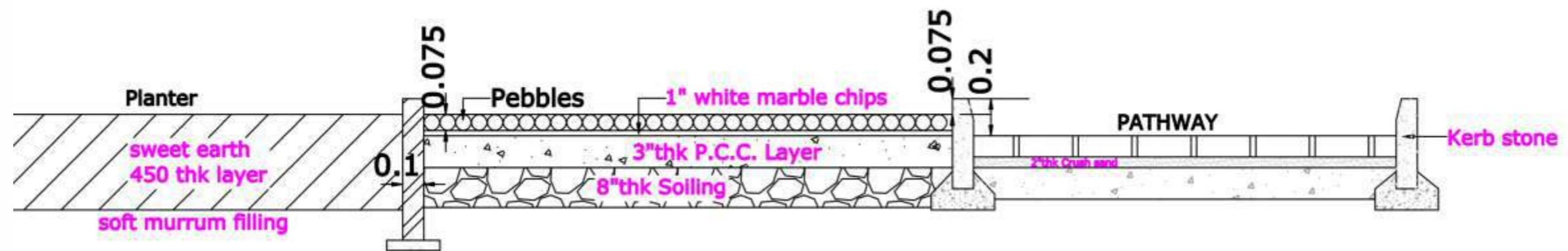
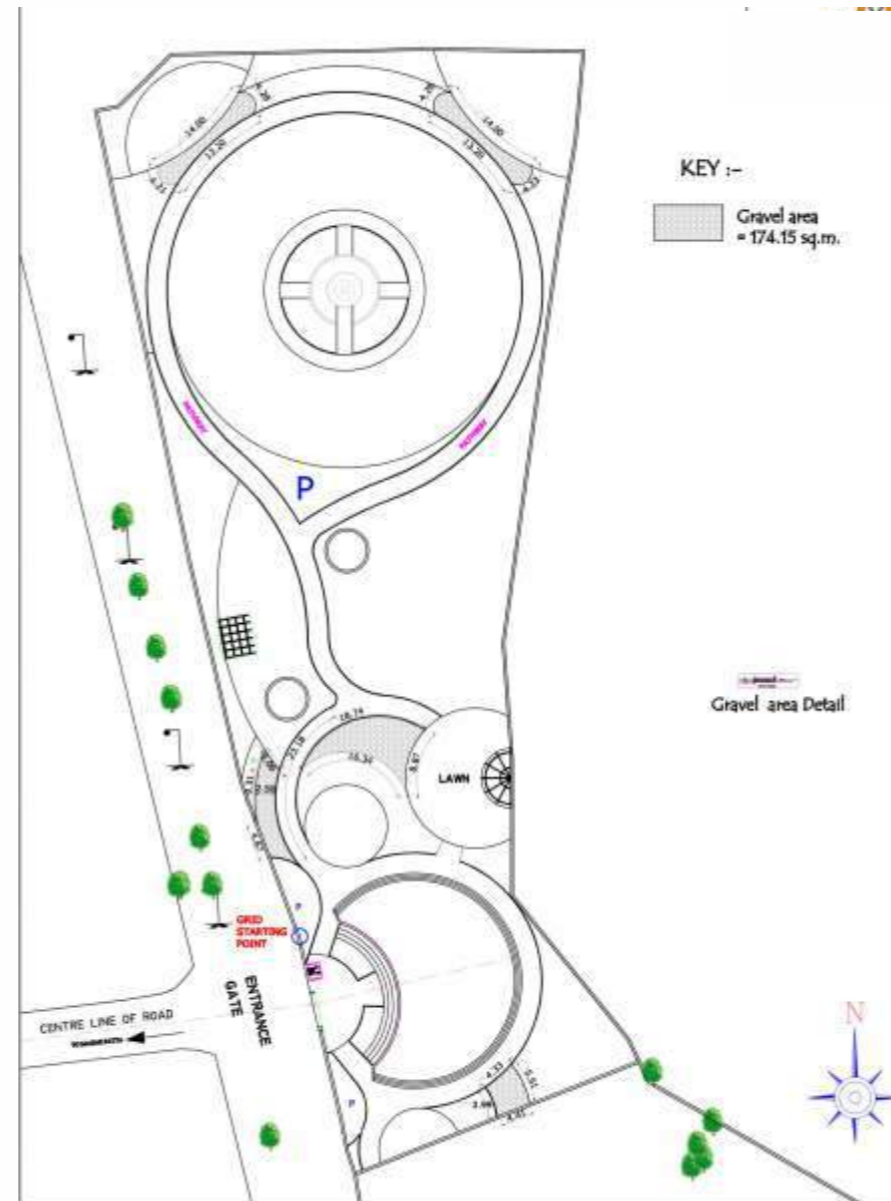

Working Drawings For 1st Phase Kerb Stone Installation

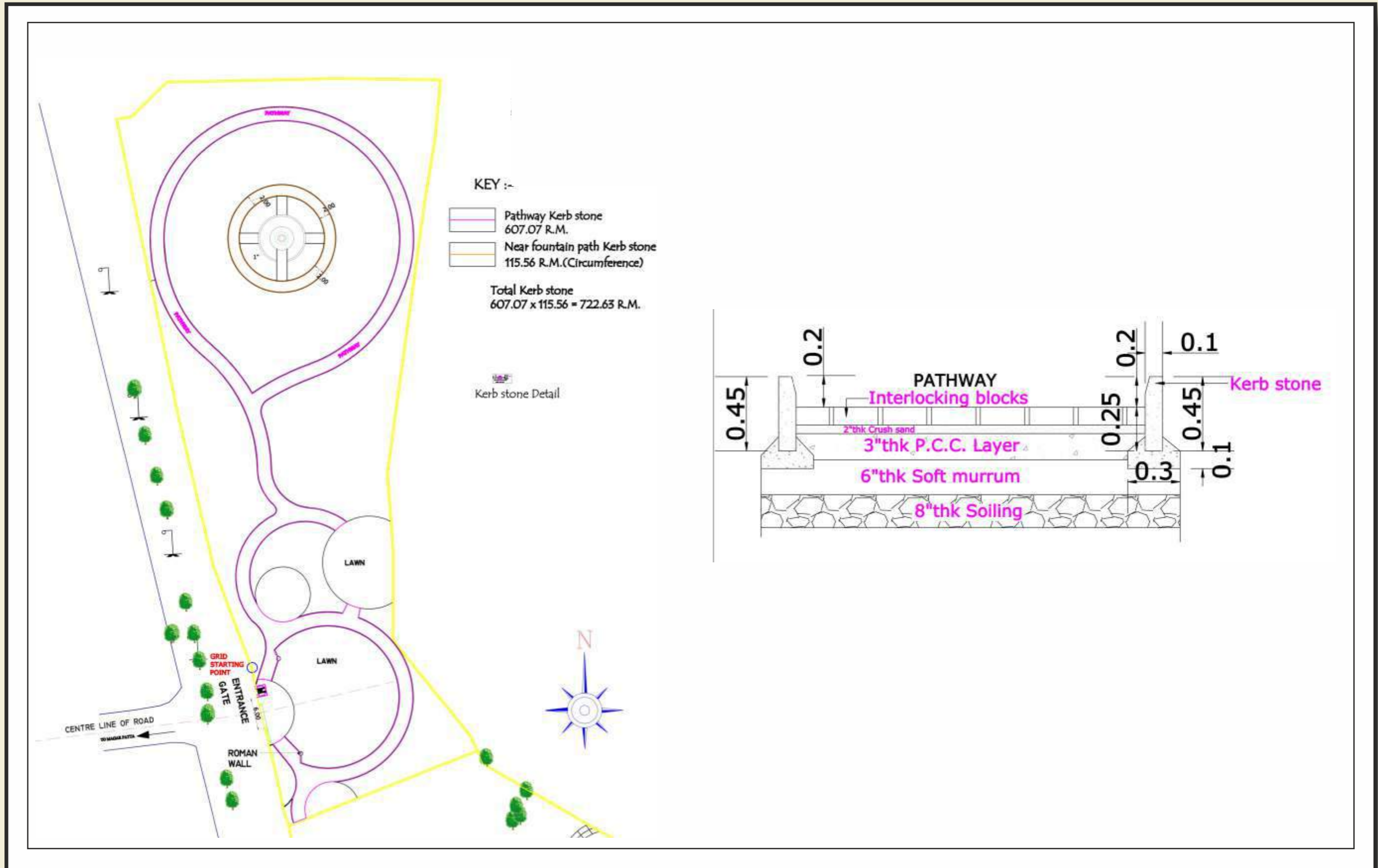

Working Drawings For Electrical Layout



Working Drawings For Pathways

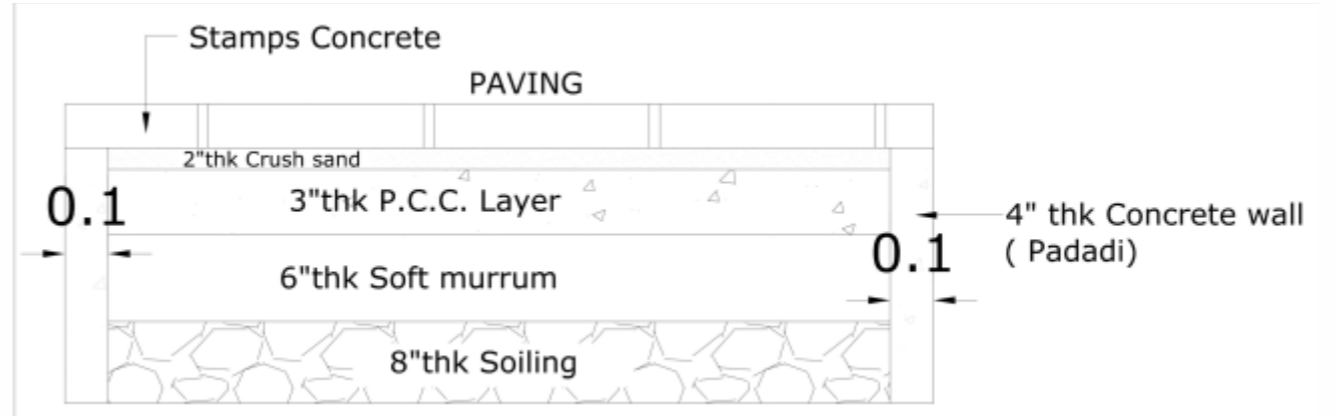
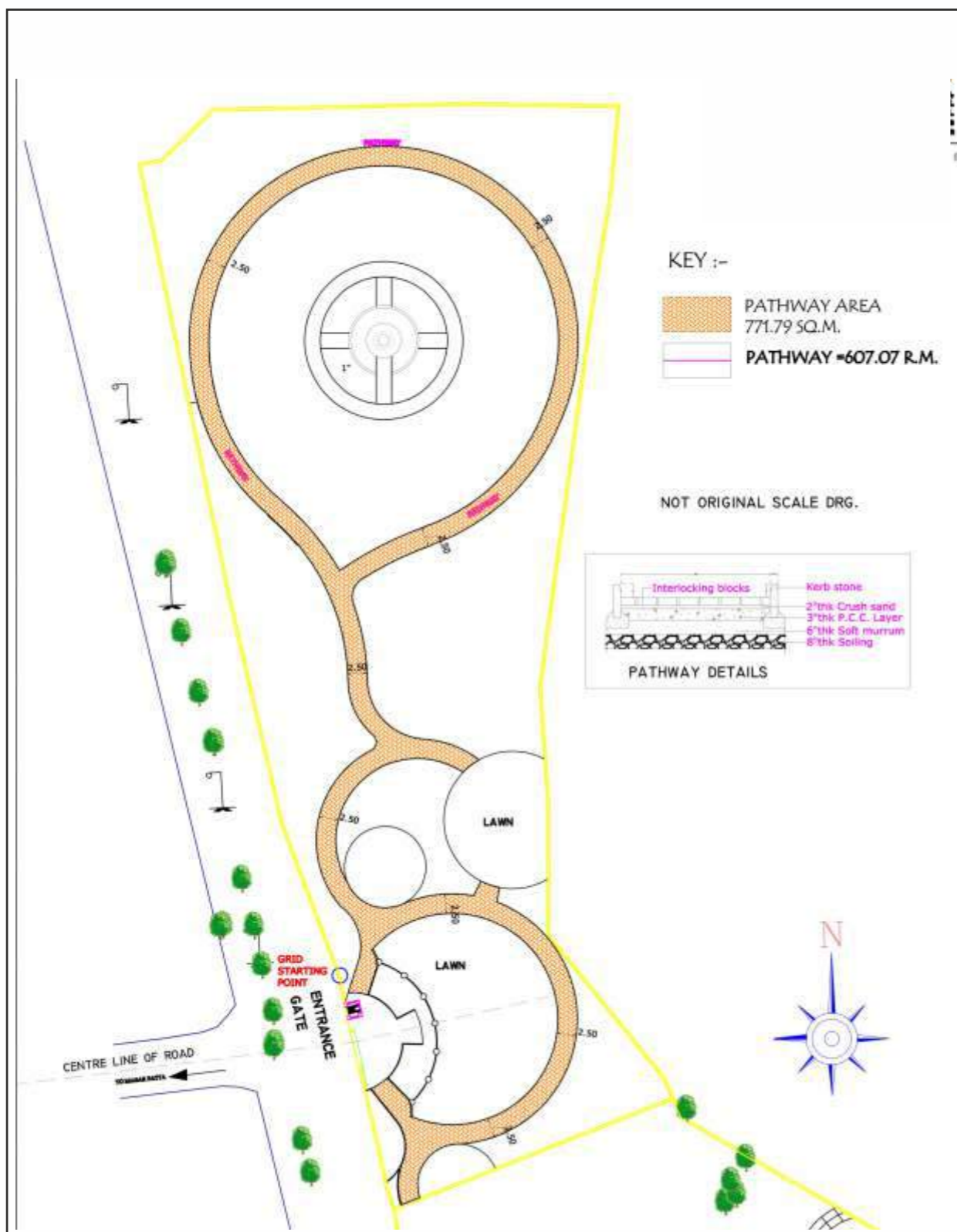

Paving Details

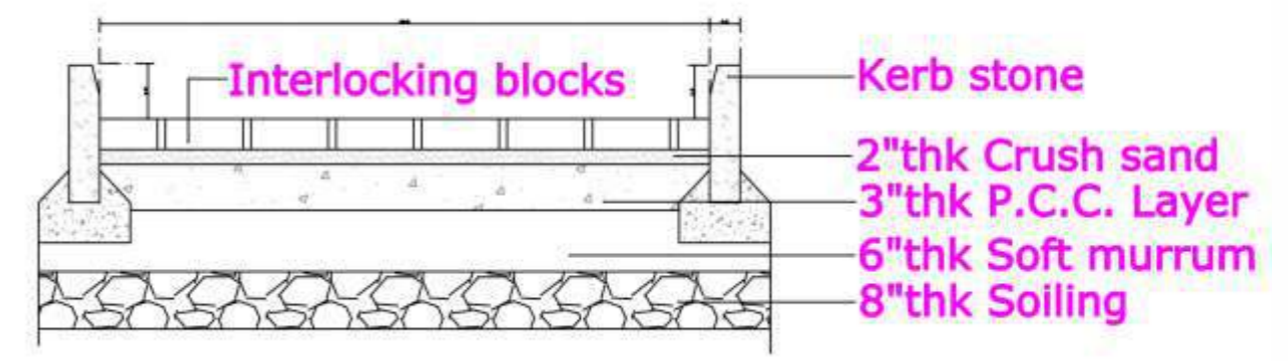

Pathway Details

Working Drawings For Nakshtra Area Line Out

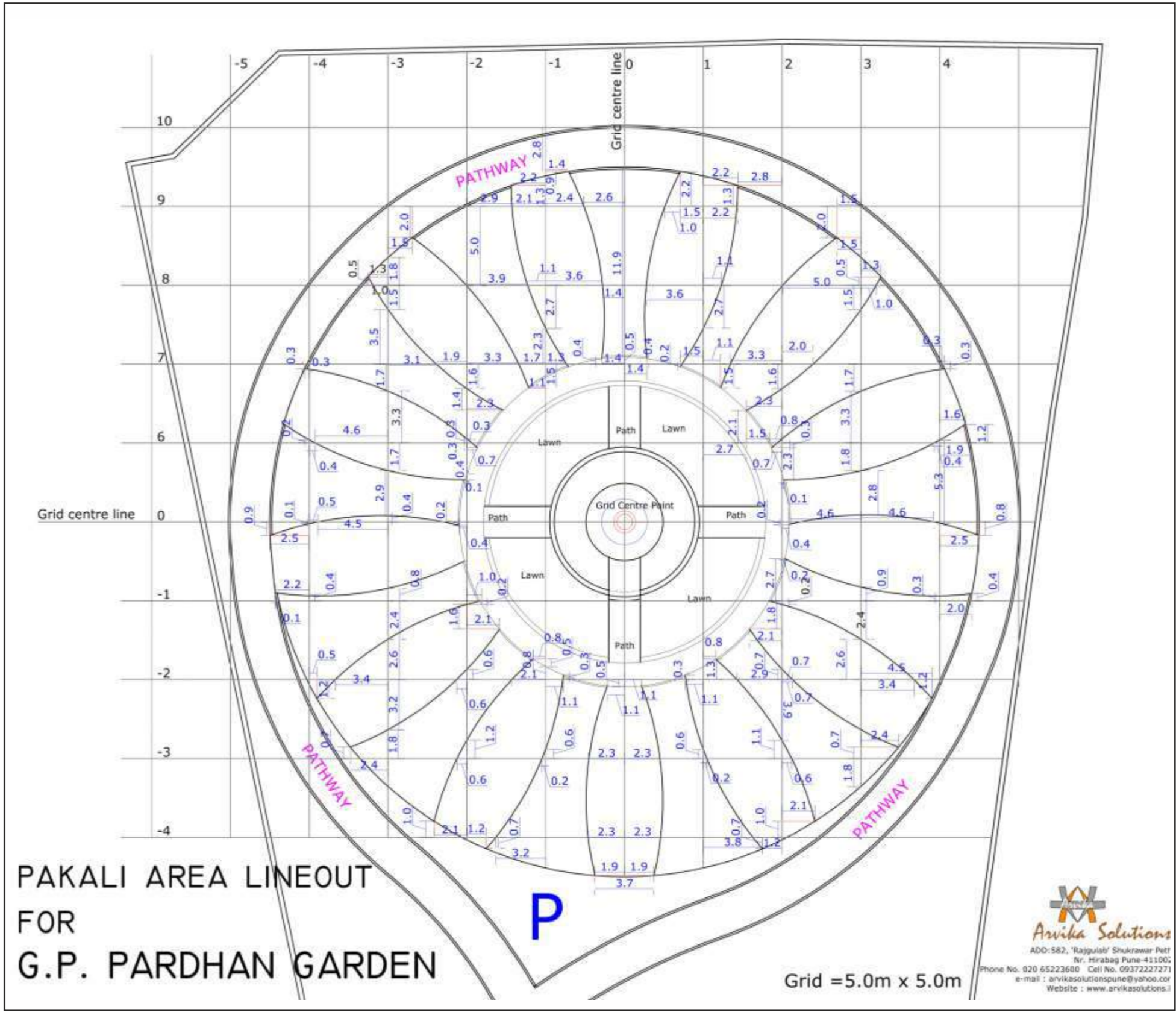

Working Drawings For Trees Plantation In Nakshtra Area

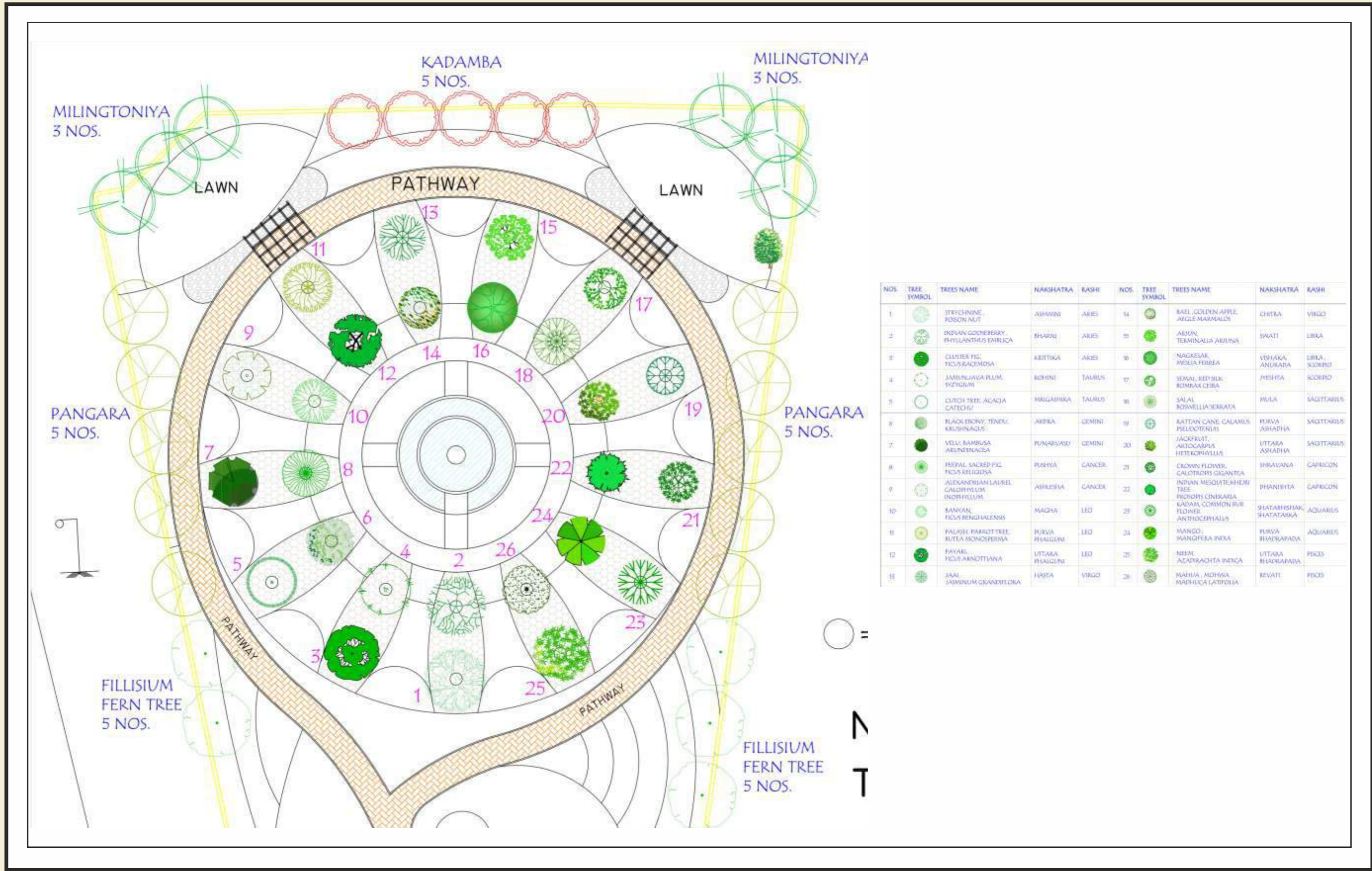

NOS.	TREE SYMBOL	TREES NAME	NAKSHATRA	RASHI	NOS.	TREE SYMBOL	TREES NAME	NAKSHATRA	RASHI
1		STRECHNINE ROSON NUT	ASHWINI	ARIES	14		BAEL, GOLDEN APPLE, JEEGEL MAMMALOS	CHITRA	VIRGO
2		INDIAN GOCHERRY, PHYLLANTHUS ENRICA	BHARNI	ARIES	15		ALUN, TERMINALLIA ARJUNA	SWATI	LIBRA
3		CLUSTER FIG, FICUS BACIFLOSA	KRITIKA	ARIES	16		NACKESAK, MUSA FERREA	SPHAKA, ANURATA	LIBRA, SCORPIO
4		JAMUN, JAVA PLUM, SYZIGIUM	ROHINI	TAMBUS	17		SEMAL, RED SILK, KOMPAK CEBA	JYESHHA	SCORPIO
5		CUTCH TREE, ACACIA CATECHU	MUGASHIRA	TAMBUS	18		SALAI, BOSWELLIA SERBATA	MULA	SAGITTARIUS
6		BLACK BERRY, TENDU, KRUSHNAGULU	ARJUNA	GEMINI	19		KATTAN CANE, CALAMUS PEUCOTENUS	MULA, ASHADHA	SAGITTARIUS
7		VELU, MAMBUKA, AELYNINACSA	PUNARVASU	GEMINI	20		JACKFRUIT, ALTOCAPUS HETTEROPHYLLUS	UTTARA ASHADHA	SAGITTARIUS
8		NEPAL SACRED FIG, FICUS RELIGIOSA	PUSHYA	CANCER	21		CROWN FLOWER, CALOTROPIS GIGANTEA	SHRAGANA	CAPRICORN
9		ALEXANDRIAN LAUREL, CALCHY PLUM, INDIAN PLUM	ASHLESHA	CANCER	22		INDIAN MESQUITE, HEMU TREE, FICUS LINDELLIA	DHANISHTA	CAPRICORN
10		BANYAN, FICUS BENGHALENSIS	MAGHA	LEO	23		KADAM, COMMON PURI FLOWER, ANTHOCEPHALUS	SHATABHISHAK, SHATATARA	AQUARIUS
11		PALASH, PARROT TREE, BUTEA MONOSPERMA	MULA	LEO	24		MANGO, MANGIFERA INDIA	MULA, BHADRAPADA	AQUARIUS
12		PAYAL, FICUS ARBODTIANA	UTTARA BHADRAPADA	LEO	25		NEEM, AZADIRACHTA INDICA	UTTARA BHADRAPADA	PISCES
13		JALAI, JASMINUM GRANITIFLORA	HASTA	VIRGO	26		MAHUA, MADHVA, MADHUCA LATTIFOLIA	REVATI	PISCES

Working Drawings For Seatings In Nakshtra Area

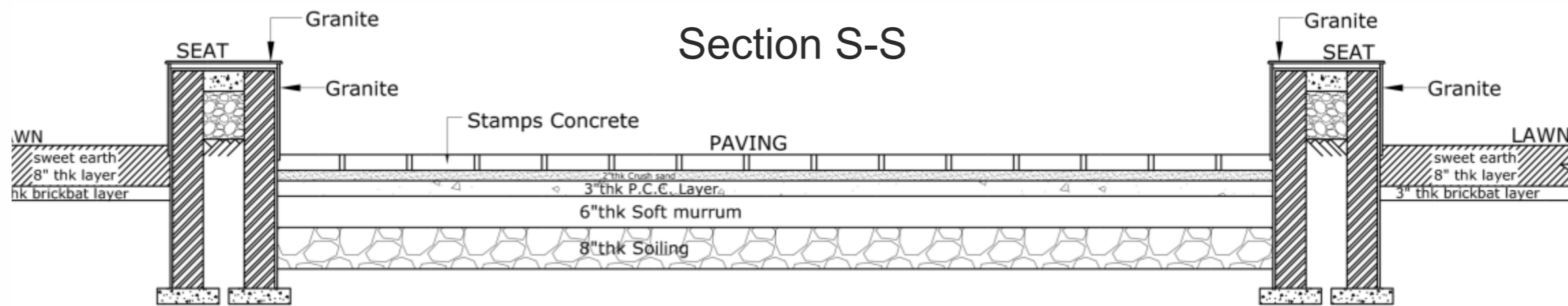
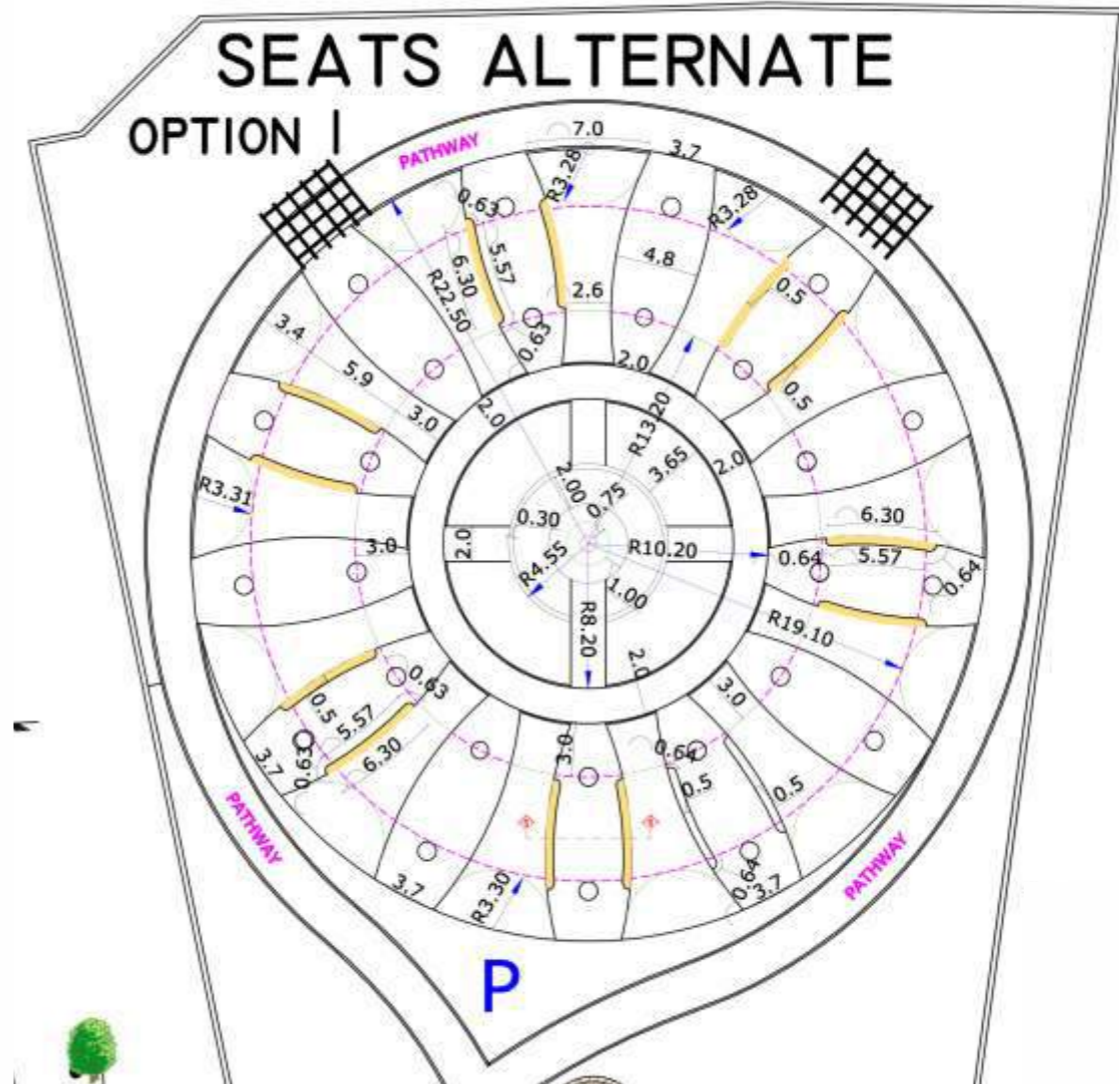
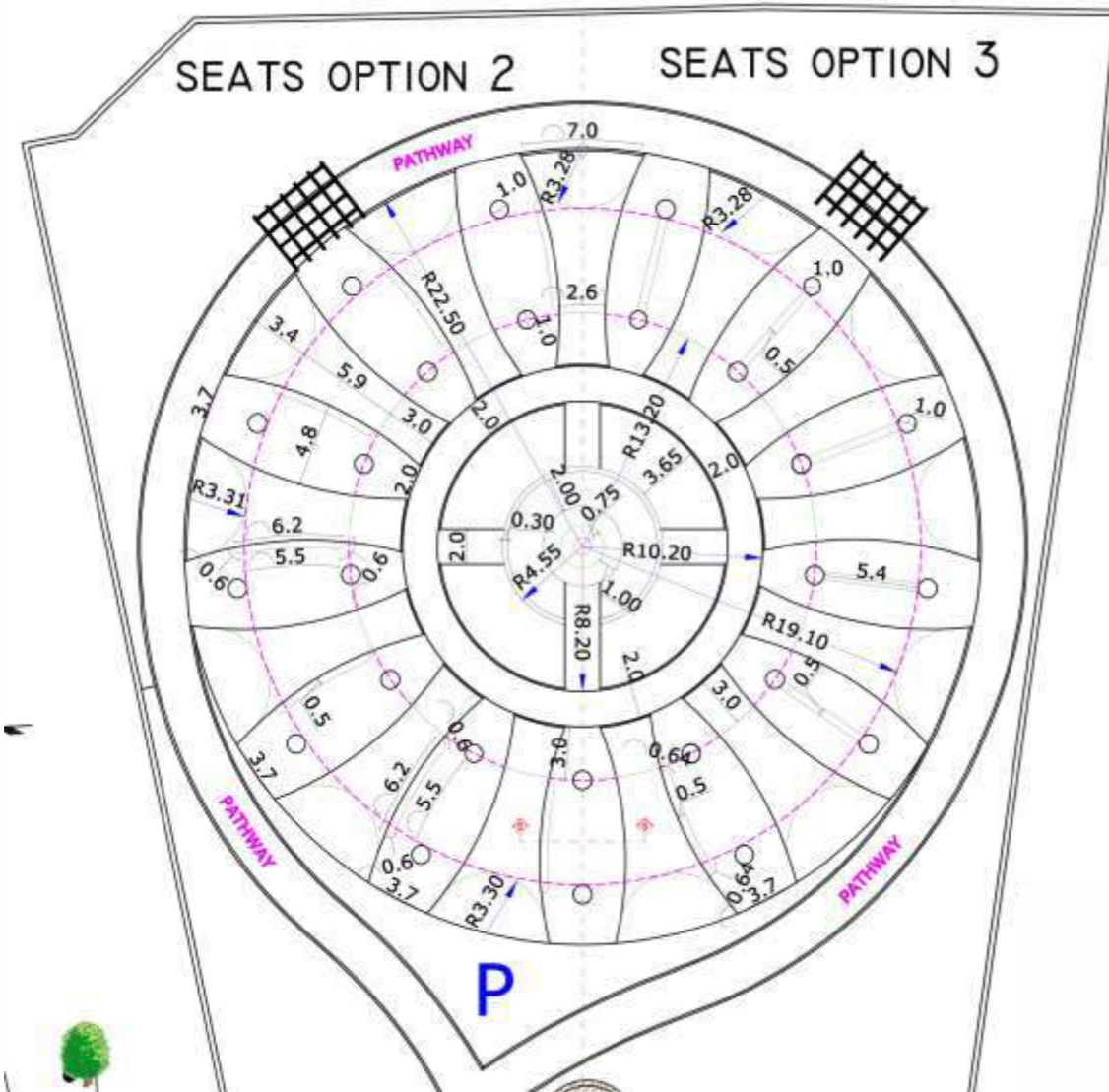

Rendered Images Of Central Area



Rendered Images Of Roman Pergola



Rendered Images Of Water Body



Rendered Images Of Nakshatra Garden Area



Rendered Images Of Children Play Area



Site Details

Client : Pune Smart City Development Corporation Pvt. Ltd.

Site : Nr. Oakwood, Baner Pune

Space under scope of work : Place Making Site

Area under scope of work : 1200 sqm

Scope of work : Thematic designing of Sports area,

Softscape, hardscape

Duration : 2018 - 2019

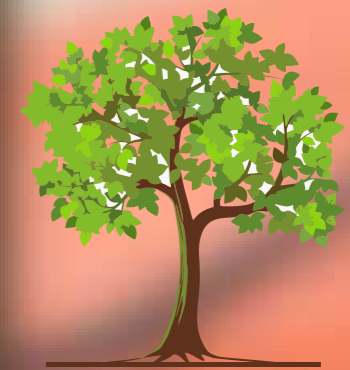

A L D S

**ARVIKA LANDSCAPE DESIGNS
SOLUTIONS PVT. LTD.**

**An ISO 9000:2015
Certified Company**

Trees Plantation Plan

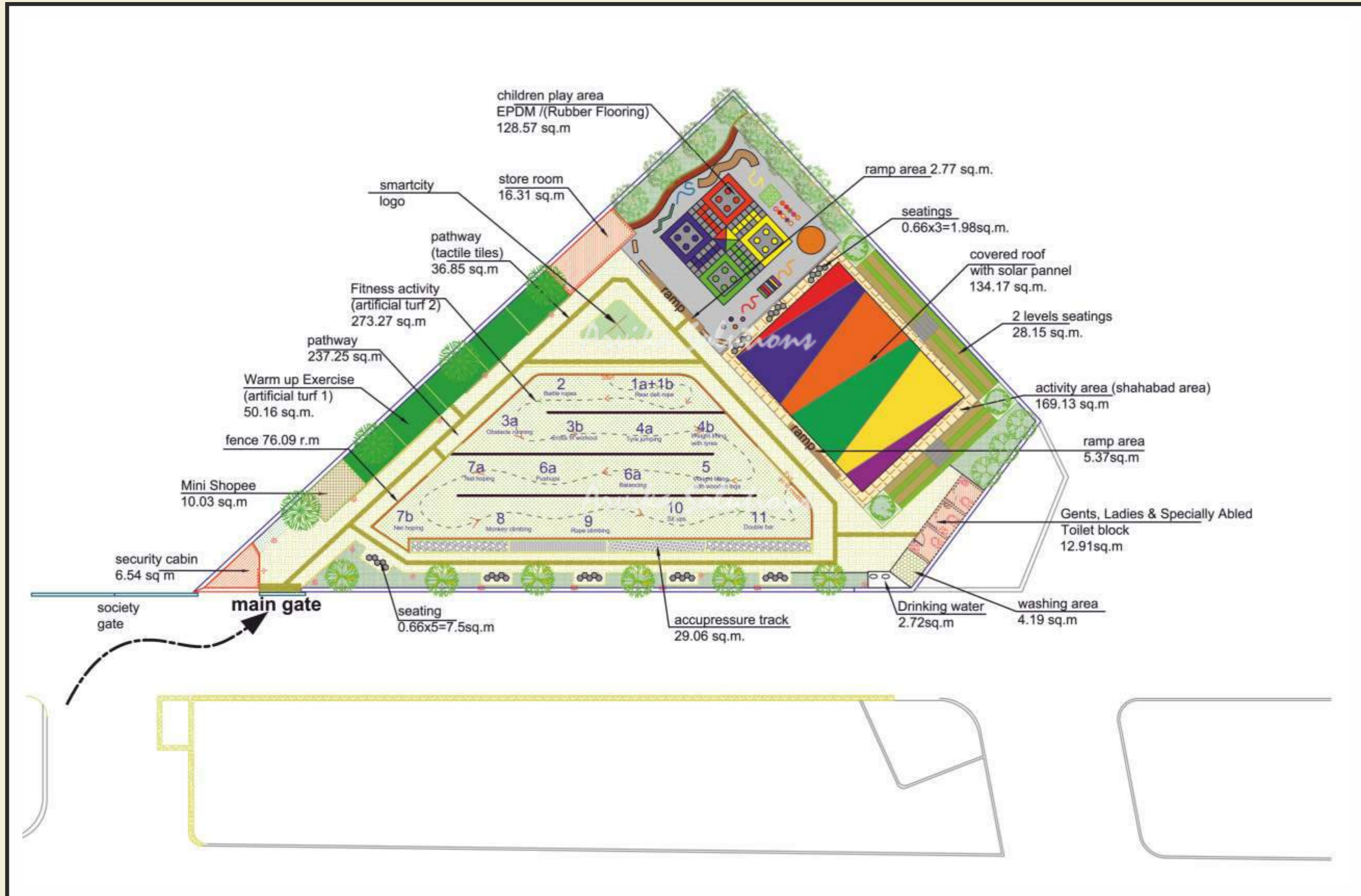

Activity Plan

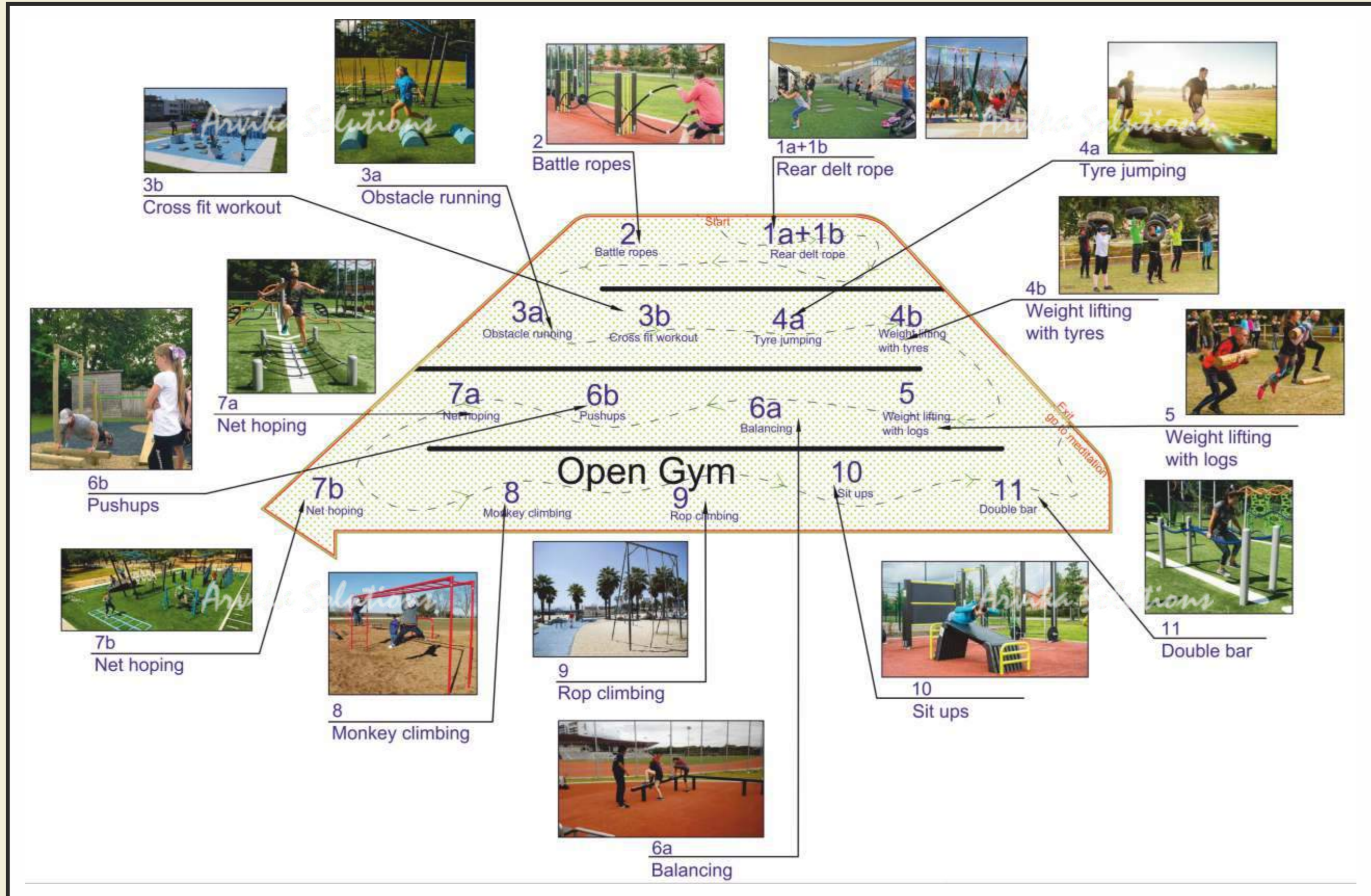

Flow & Photos of Equipements

1a



Rear Delt Rope

1b



Rear Delt Rope

2



Battle Ropes

3a



Obstacle Running

3b



Cross Fit workout

4



Tyre Jumping

4



Weight Lifting With Tyres

5



Weight lifting with Logs

6a



Balancing

6b



Pushups

7a



Net Hopping

7b



Net Hopping

8



Monkey Climbing

9



Rope Climbing

10



Sit ups

11



Double Bar

Rendered Views



Rendered Views

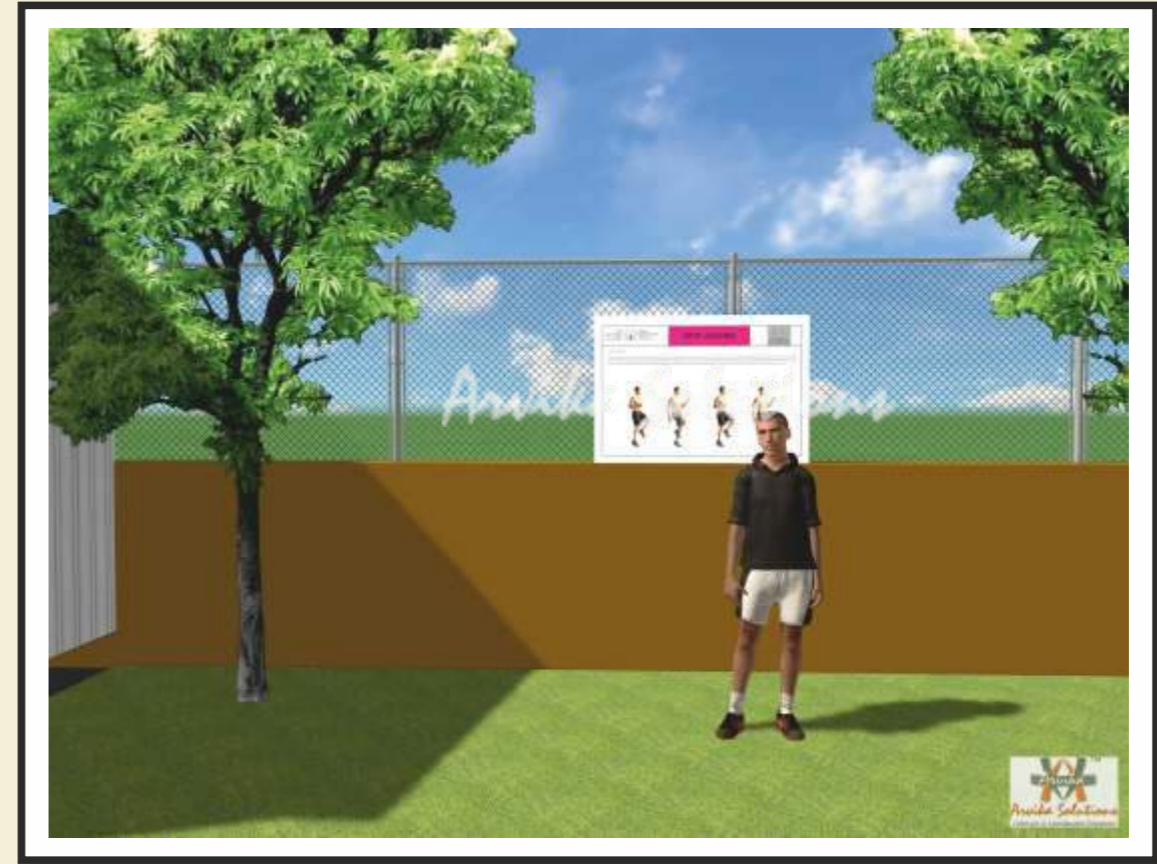

Rendered Views



Plantation Plan

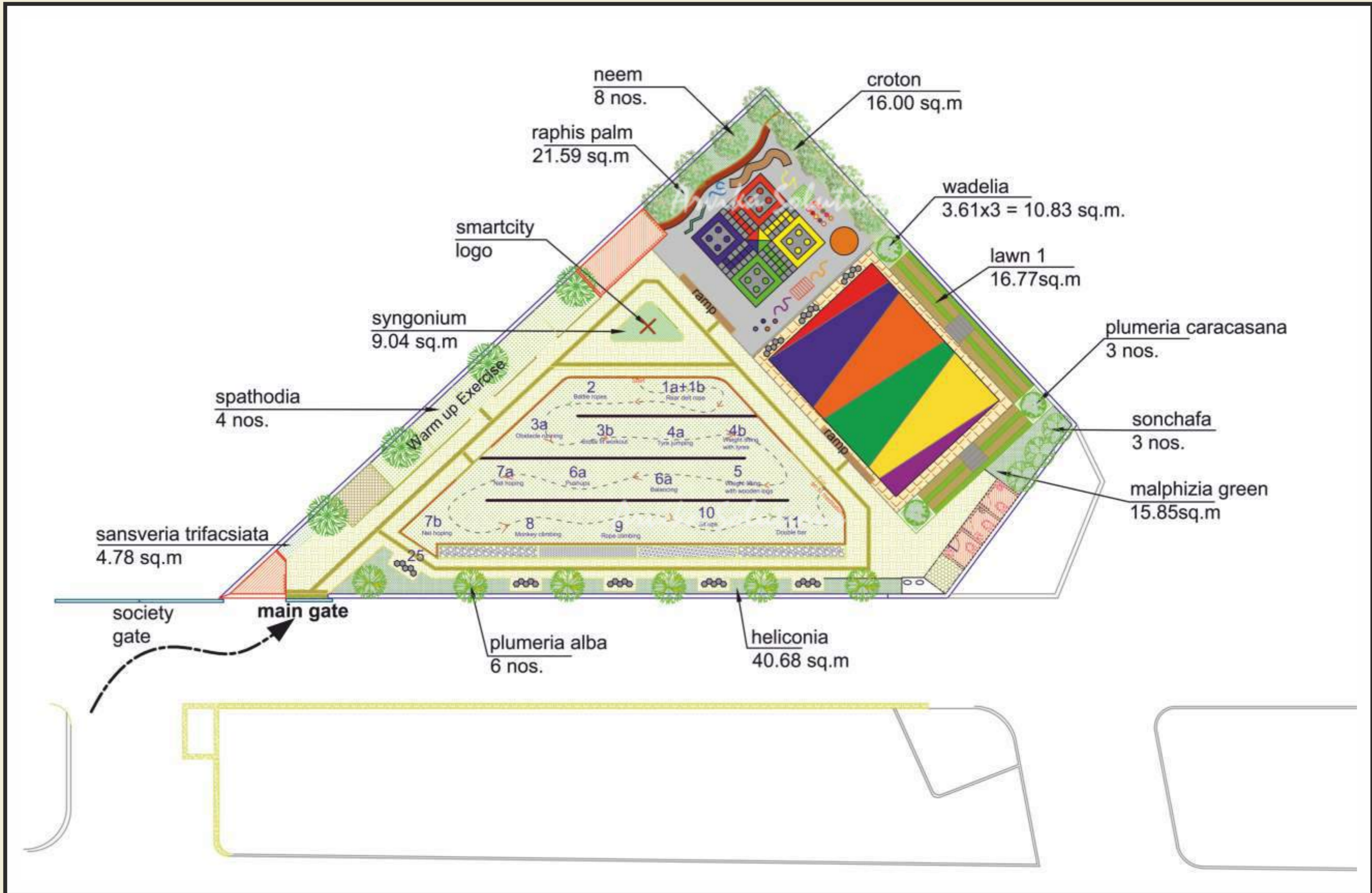

Photos of Plants to be used

1



Plumaria Alba

2



Sansveria

3



Spathodia

4



Syngonium Copper

5



Kadamb

6



Raphis palm

7



Azaradicta Indica (Neem)

8



Croton Petra

9



Waddleya Trilobata

10



Plumeria Caracasana

11







Sonchapha

12



Heliconia

Electrical Layout

SCHEDULE OF LIGHTS		
SYMBOL	DESCRIPTION	QUANTITY
	GARDEN POLE LIGHT- 30W CFL	7 nos.
	BOLLARD LIGHT- 18W CFL	15 nos.
	LED LIGHT 40 w	4 nos.
	WALL WASH SPIKES	15 nos.



Material Photos



Concrete Seating

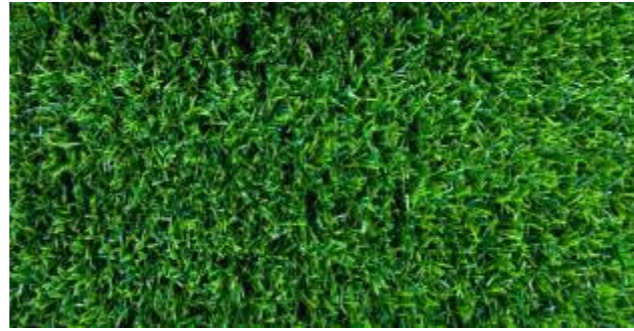

Artificial Turf



Coping stone for Amphitheater Kota Stone



Rubber Flooring (EPDM)



Paving Block with Tactile Tile



Shahbad Stone



K LITE French Orna Lighting Poles
KP 8258



Main Gate, Compound Wall & Branding

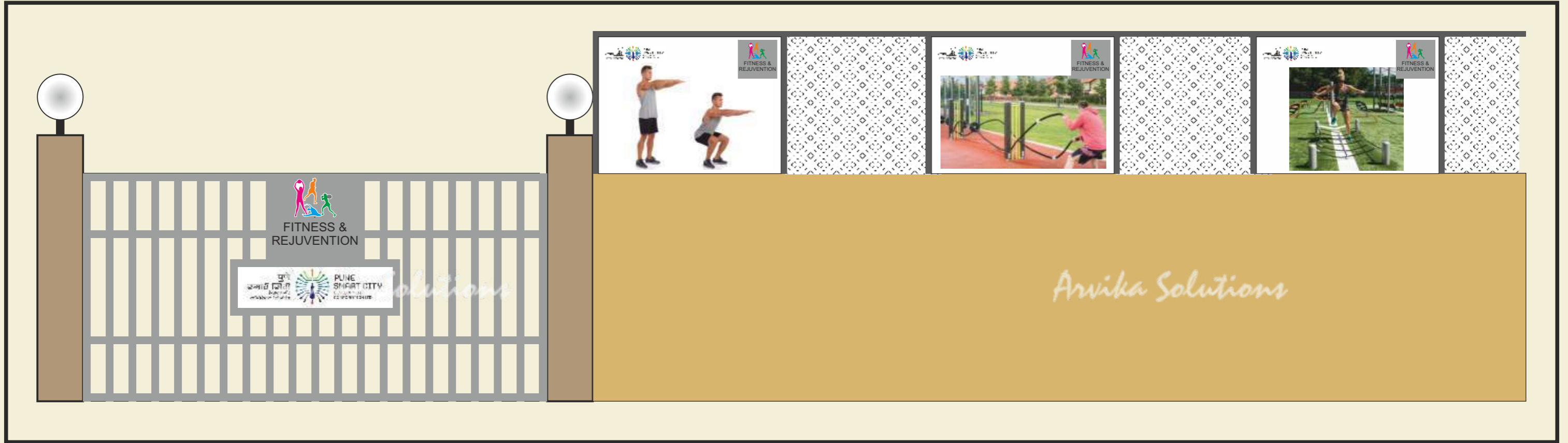

Signage





Landscape Designing Residential Projects



A L D S

**ARVIKA LANDSCAPE DESIGNS
SOLUTIONS PVT. LTD.**

**An ISO 9000:2015
Certified Company**

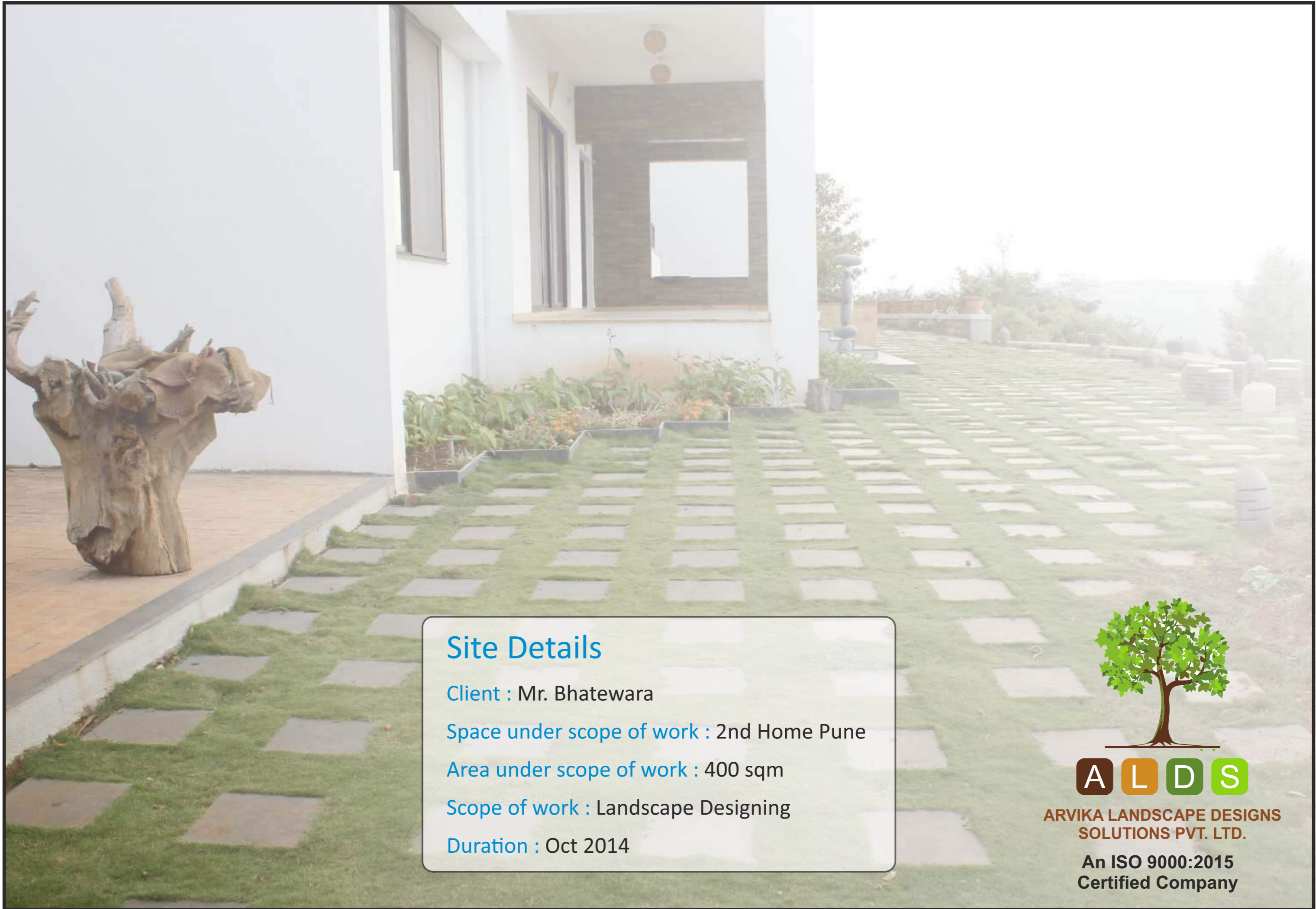

Site Details

Client : Mr. Bhatewara

Space under scope of work : 2nd Home Pune

Area under scope of work : 400 sqm

Scope of work : Landscape Designing

Duration : Oct 2014



A L D S

**ARVIKA LANDSCAPE DESIGNS
SOLUTIONS PVT. LTD.**

**An ISO 9000:2015
Certified Company**

Presentation Plan



Working Drawing for Tiling

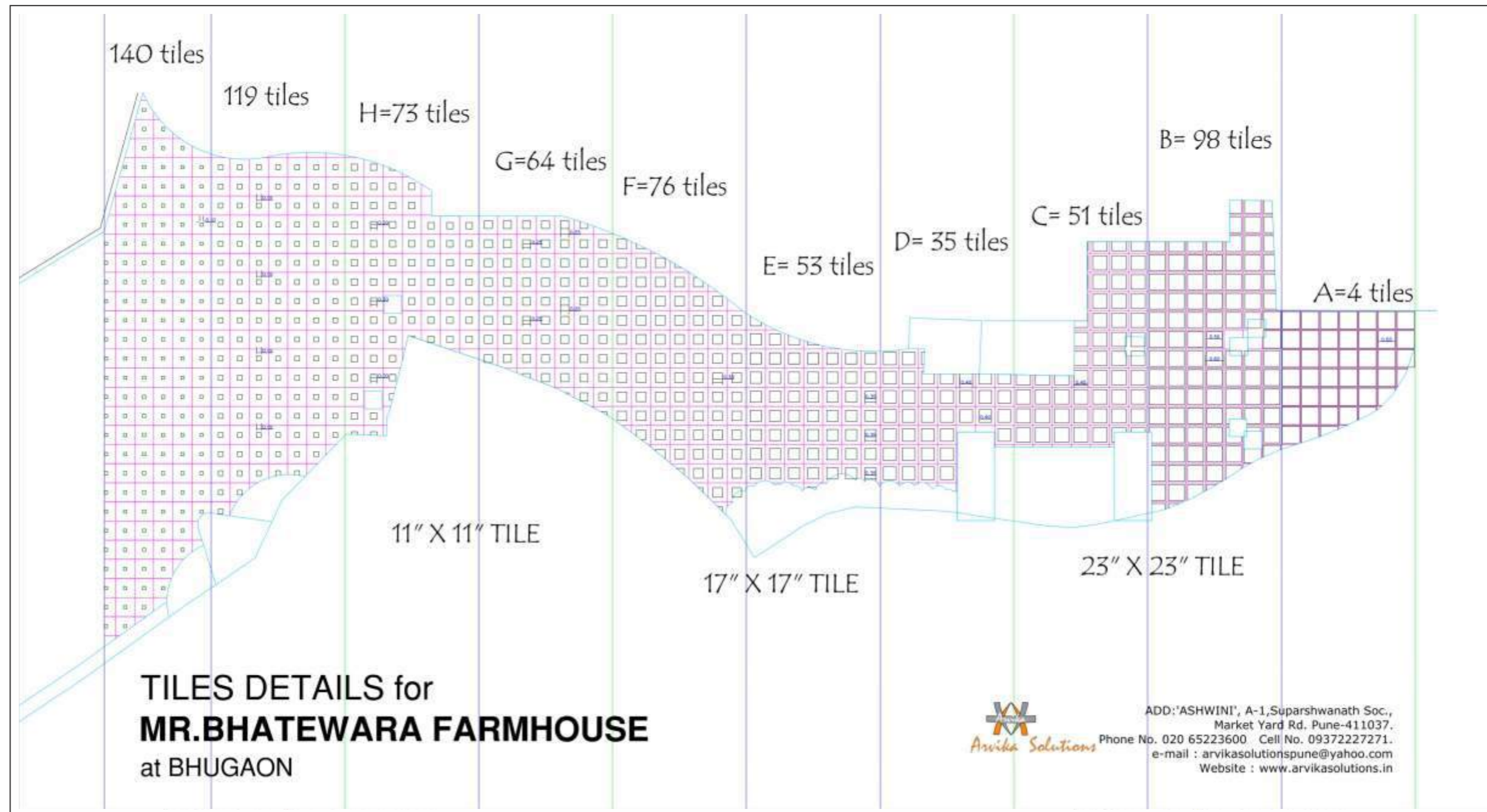

Working Drawing for Electrical Works

SCHEDULE OF LIGHTS

SYMBOL	DESCRIPTION	QUANTITY
SL	STREET POLE LIGHT	5 nos.
DL	DIPLOCE LIGHT	5 nos.
BL	BOLLARD LIGHT-IBV/CFL	13 nos.
UL	UNDERWATER LIGHTS LED/IBV	7 nos.
WL	WALKING LIGHT	19 nos.
HL	(HALOGEN)	11 nos.
SL	STADIUM	3 nos.
FL	FOCUS LIGHT	9 nos.
BL	BOLLARD LIGHT	23 nos.
SL	BLUE STAR LIGHT (LED)	27 nos.
FL	COLOURFUL FOCUS LIGHT	14 nos.
FL	FOOT LIGHT	3 nos.
FL	BLUE FOOT LIGHT	3 nos.
SL	SPIKES	1 no.

Note : Bamboo led lights not counted



LIGHTING LAYOUT for MR. BHATEWARA FARMHOUSE at BHUGAON



ADD: ASHWINI, A-1, Suparshwanath Soc.,
Market Yard Rd, Pune-411037.
Phone No. 020 65223600 Cell No. 09372227271.
e-mail : arvikasolutionspune@yahoo.com
Website : www.arvikasolutions.in



PROJECT NO. 2018/0010

PROJECT NO. 2018/0010

Site Photographs



Site Photographs



Site Photographs



Site Details

Client : Mr. Patel Residence

Space under scope of work : Bungalow

Area under scope of work : Ground level 400 sqm

Scope of work : Landscape Designing Soft scape & water body

Duration : Oct 2014



A L D S

**ARVIKA LANDSCAPE DESIGNS
SOLUTIONS PVT. LTD.**

**An ISO 9000:2015
Certified Company**

Presentation Plan



Presentation Plan

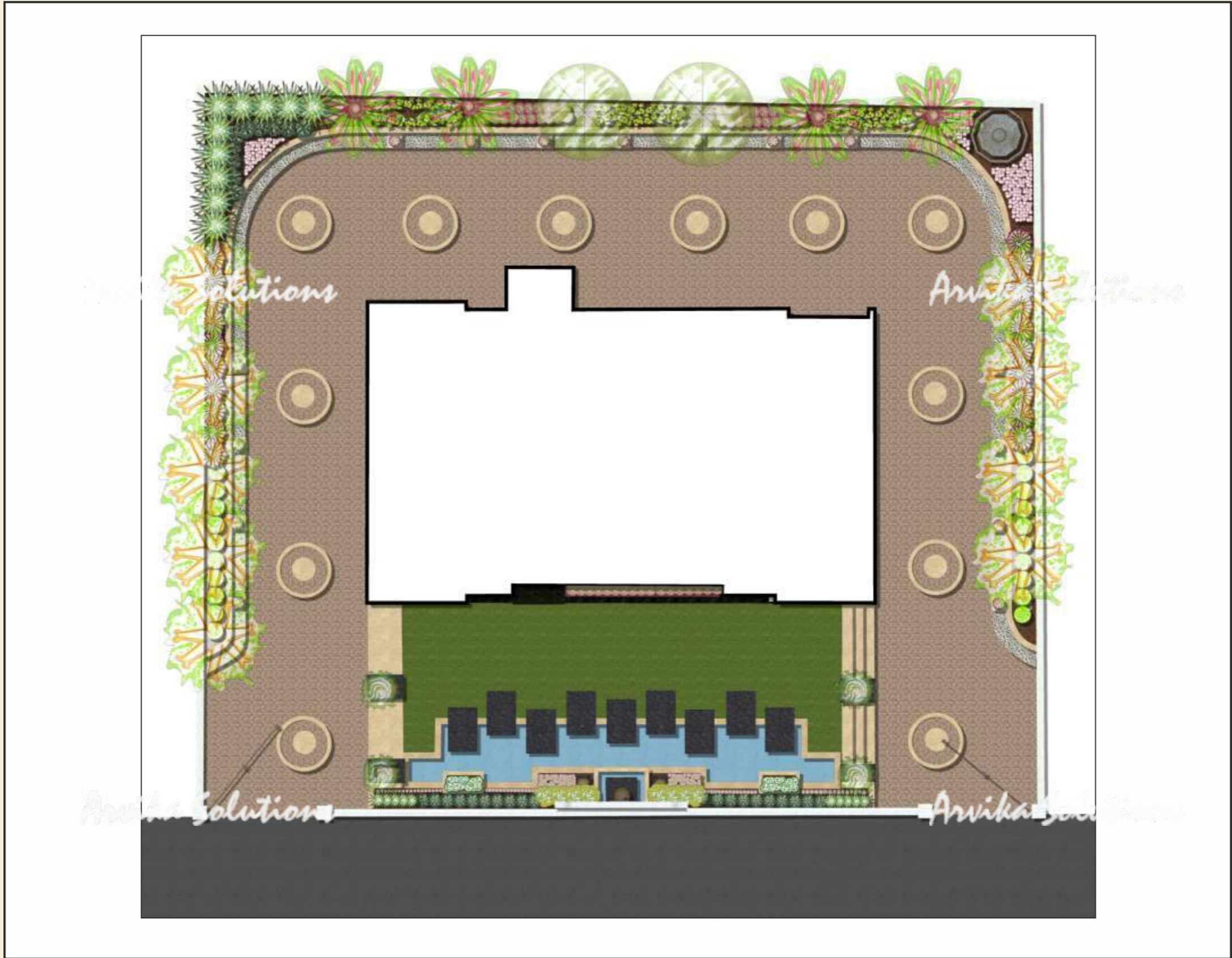

Presentation Plan



Rendered Views



Working Drawings

Archi Solutions

Archi Solutions

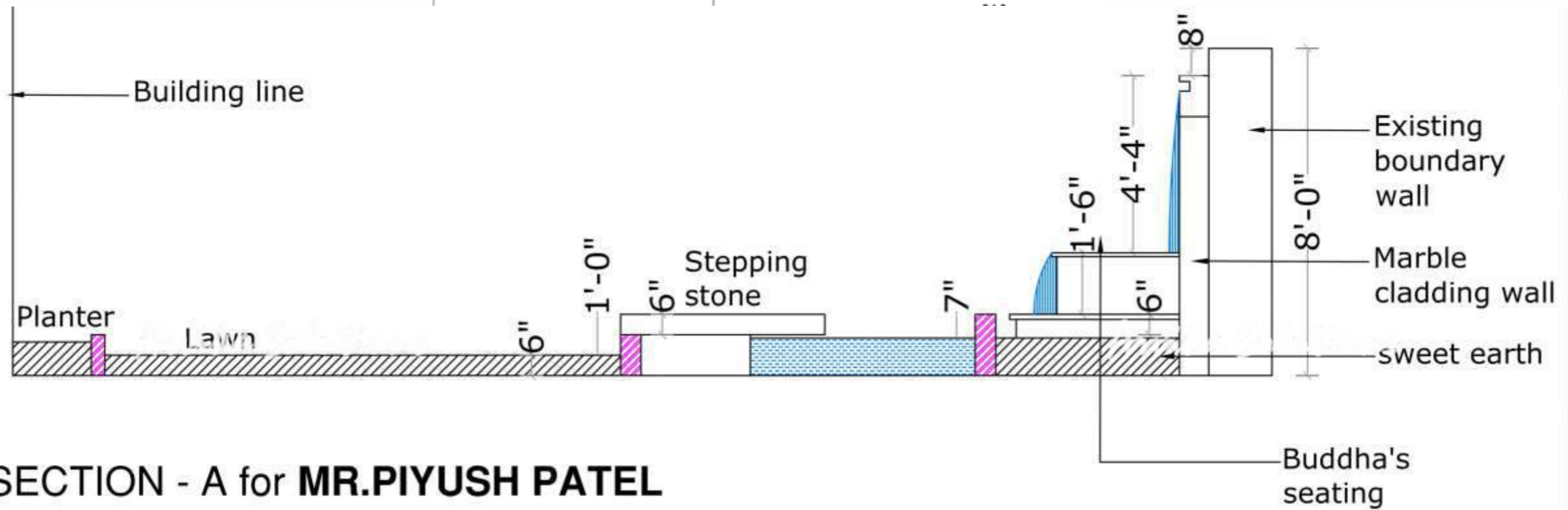
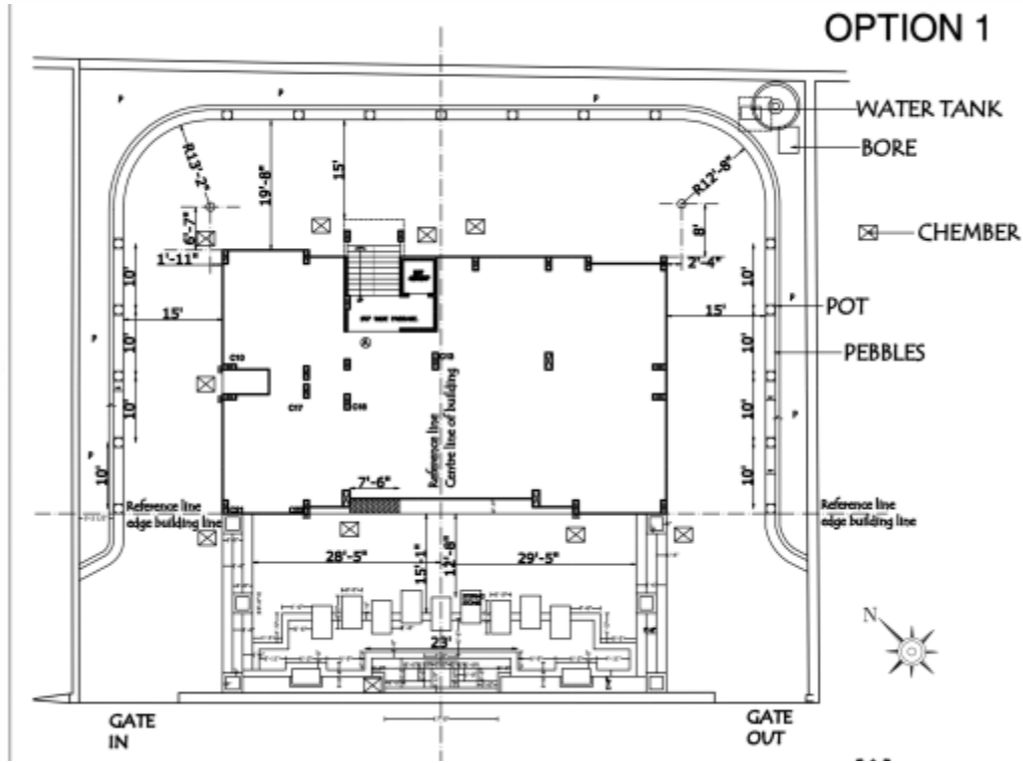

Working Drawings

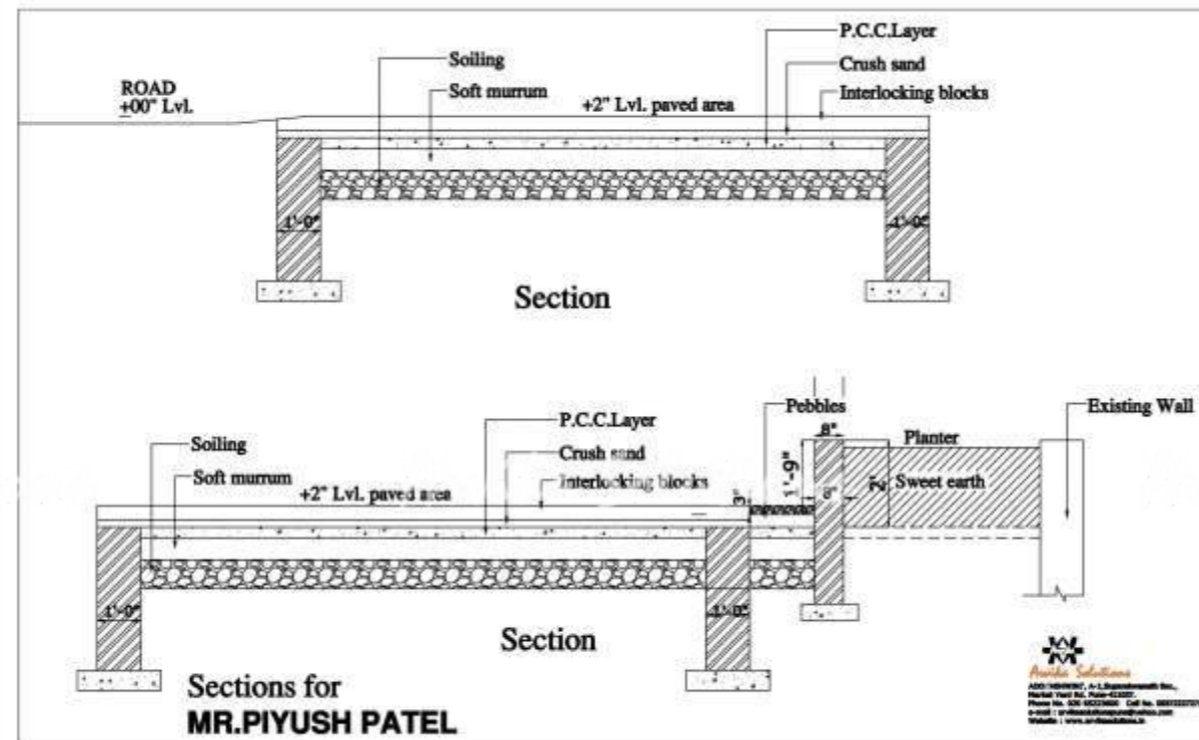
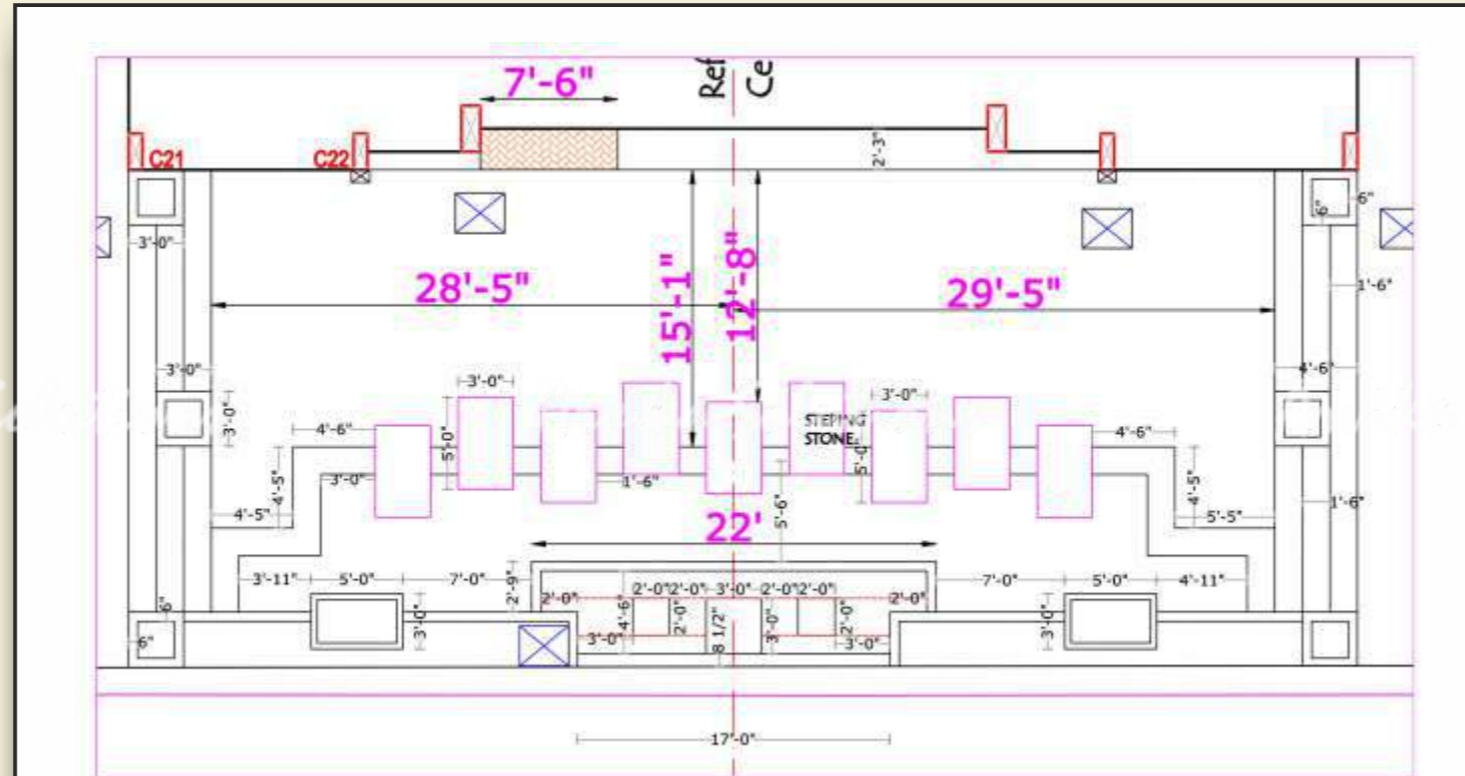

Arvika Solutions
Arvika Solutions Pvt. Ltd.
Plot No. 102, Sector 10, Gurgaon
Phone No. 012-4222222 | Fax No. 012-4222222
E-mail: arvika@arvikasolutions.com
Website: www.arvikasolutions.com

Rendered Views



Rendered Views



Rendered Views



Actual Photos





Site Details

Client : Mr. Pradeep Garewal

Space under scope of work : Residence

Area under scope of work : 350 sqm

Scope of work : Designing of Soft scape,
Water body, Civil works & Structures

Duration : 2019



A L D S

**ARVIKA LANDSCAPE DESIGNS
SOLUTIONS PVT. LTD.**

**An ISO 9000:2015
Certified Company**

Plantation Plan

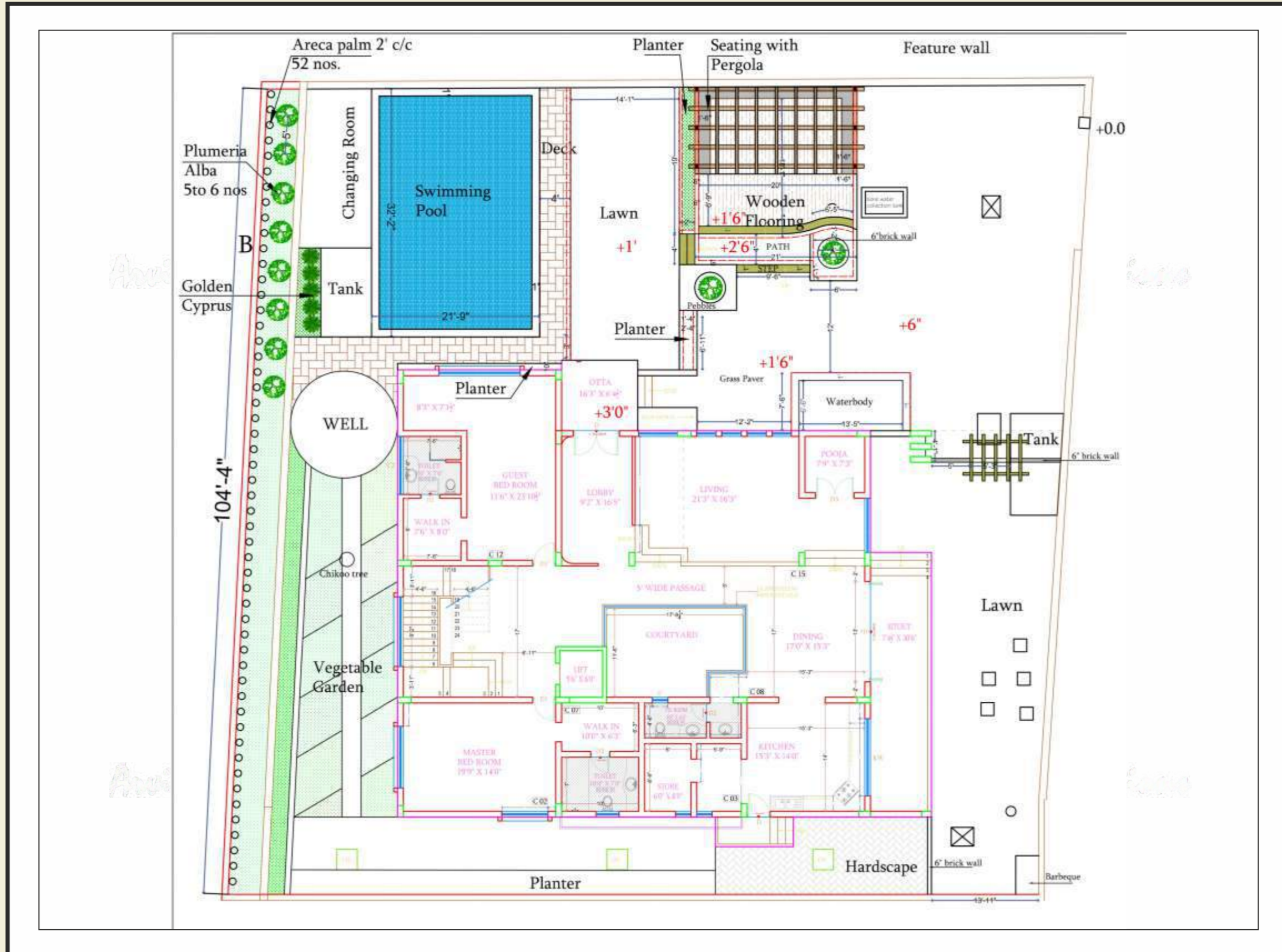

Electrical Layout Working Drawings

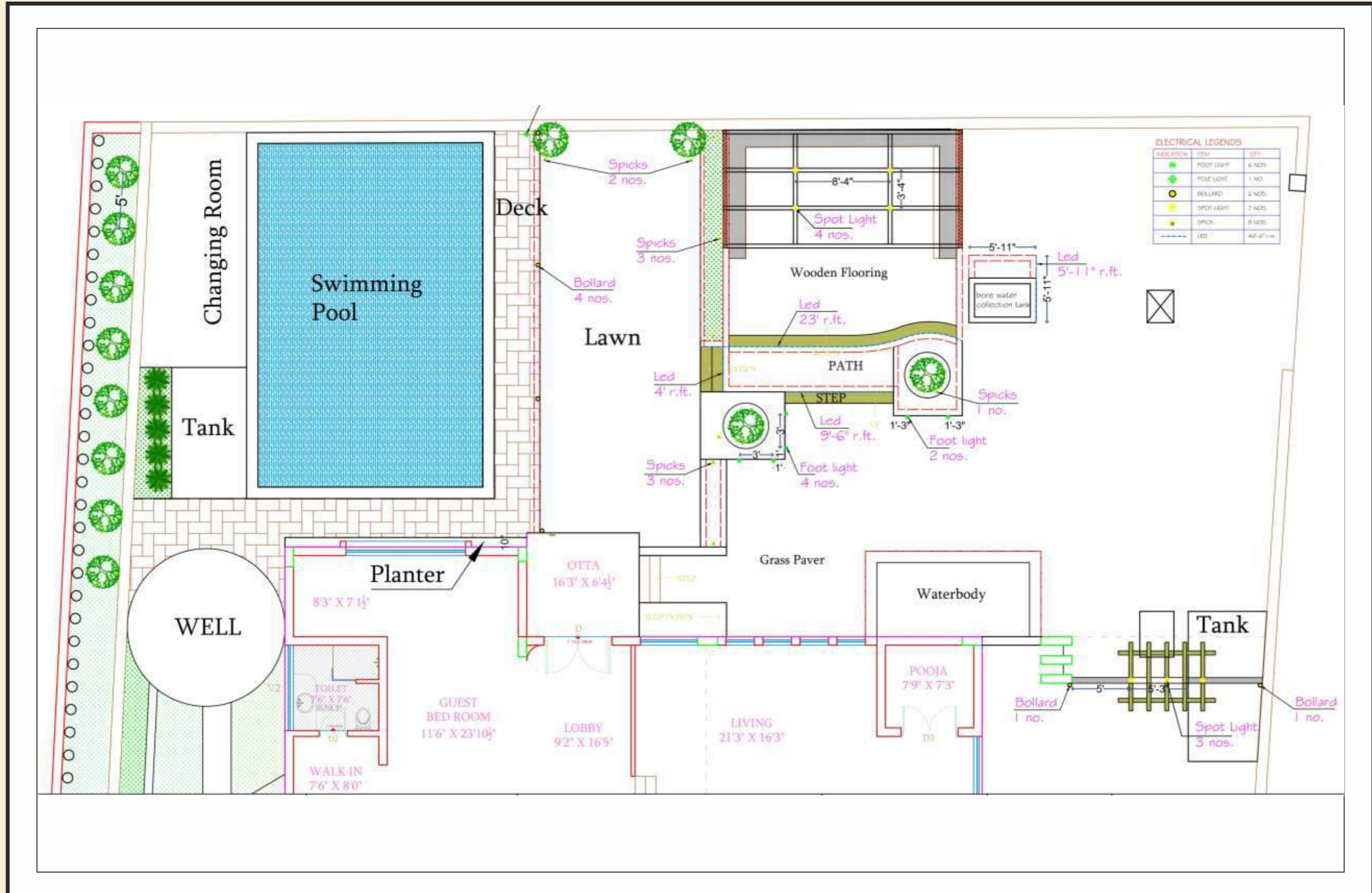

Water Body Working Drawings

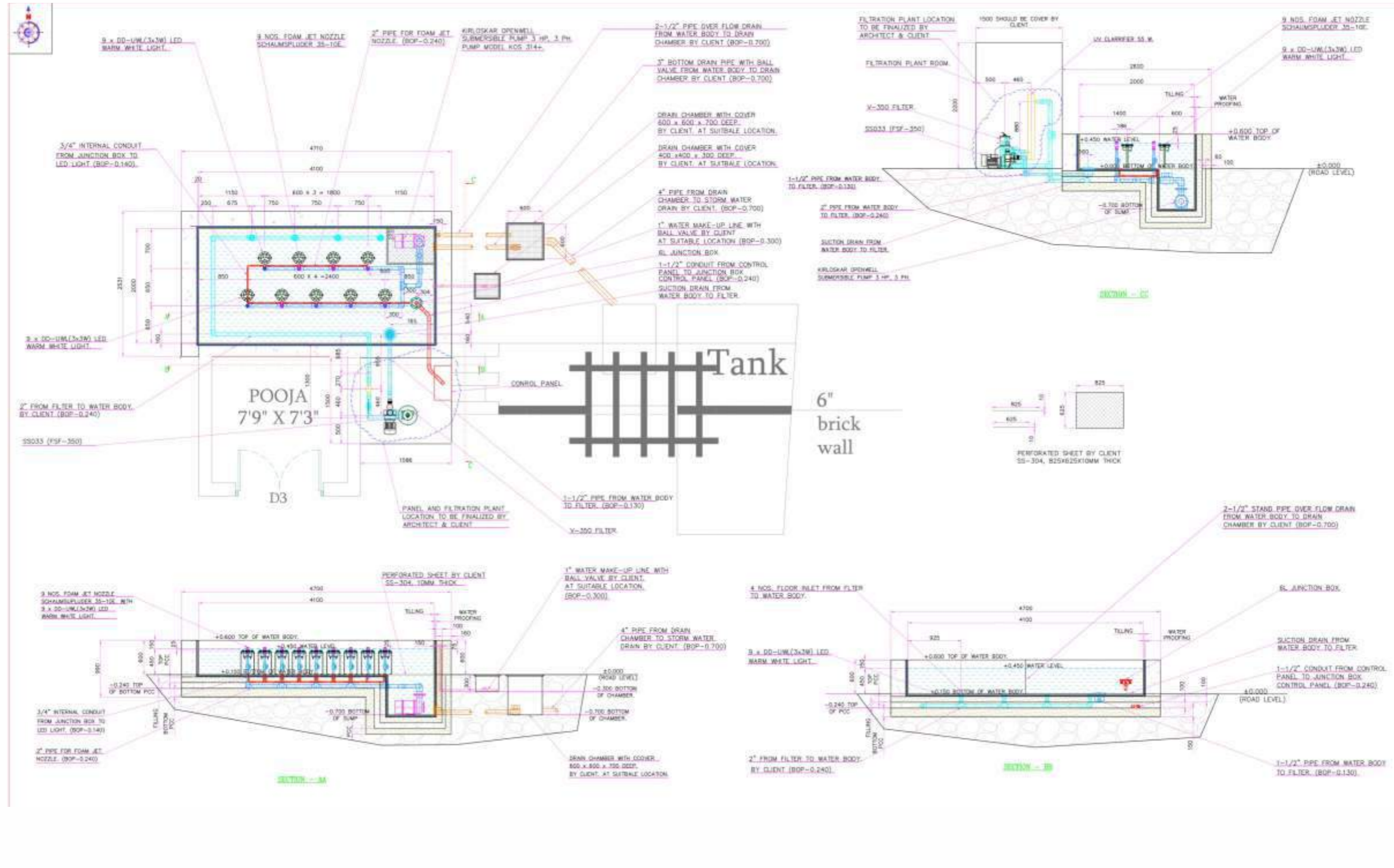

Client : **Mr. Pradeep Garewal**

Space : Residential Premies - Pune

Scope : Soft scape, Hard scape & water body (350 sqm)

Year : 2019

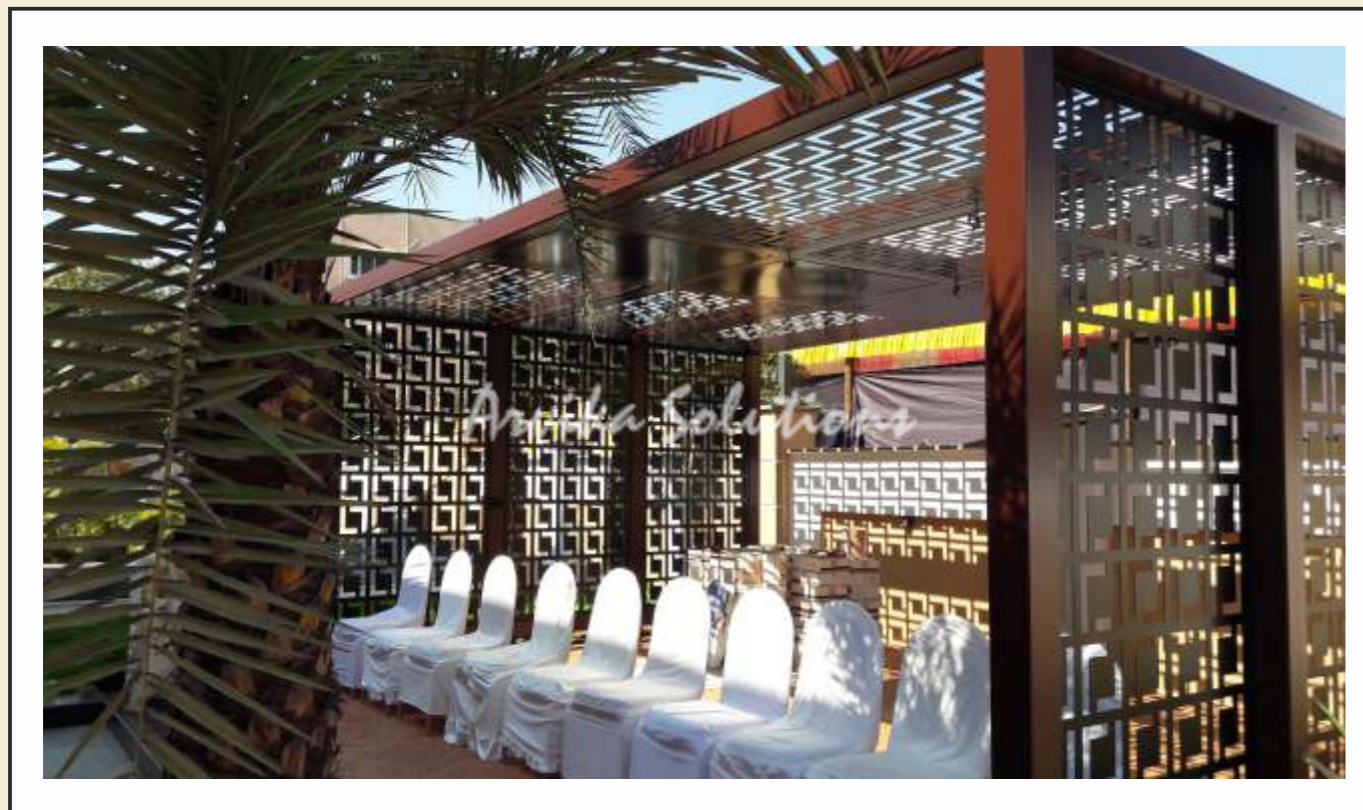



Landscape Designing Terrace Projects



A L D S

**ARVIKA LANDSCAPE DESIGNS
SOLUTIONS PVT. LTD.**

**An ISO 9000:2015
Certified Company**

Site Details

Site : JCB Excavators Ltd. (MIDC Talegaon, Pune)

Space under scope of work : Terrace

Area under scope of work : 450 sqm

Scope of work : Designing of Softscape,
water body, hardscape Execution of project

Year : 2017



A L D S

ARVIKA LANDSCAPE DESIGNS
SOLUTIONS PVT. LTD.

An ISO 9000:2015
Certified Company

Plan

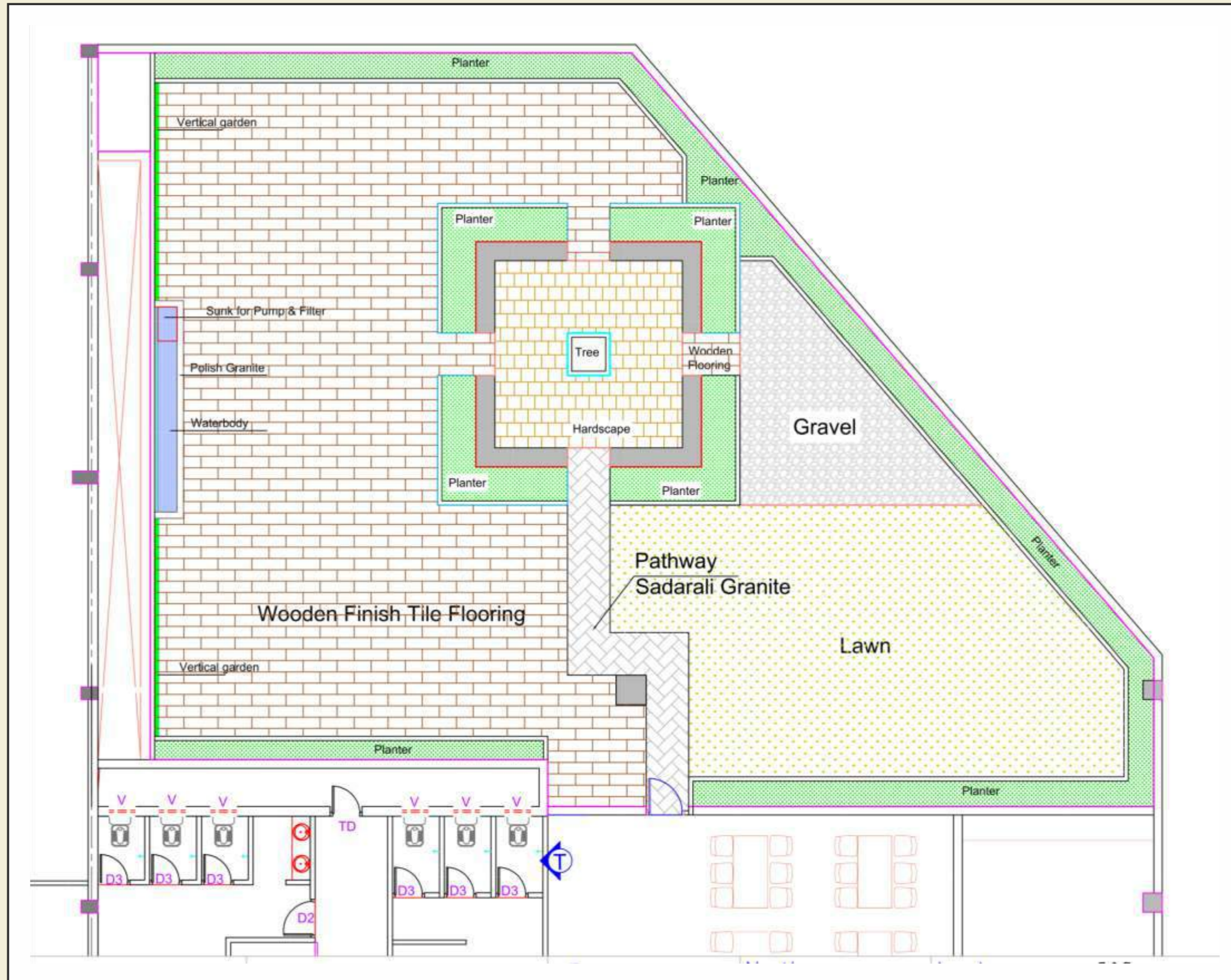

Presentation Plan

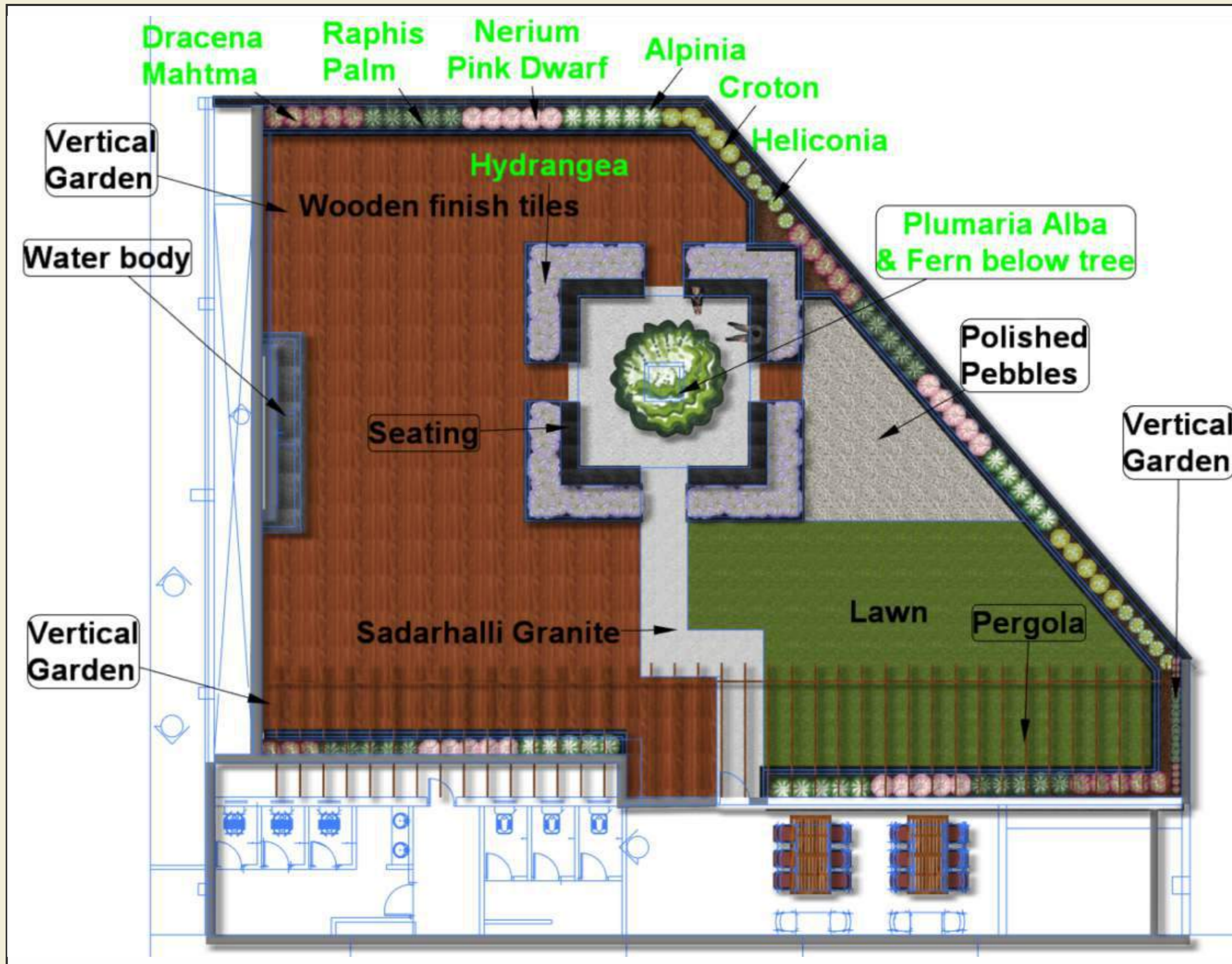

Working Drawings

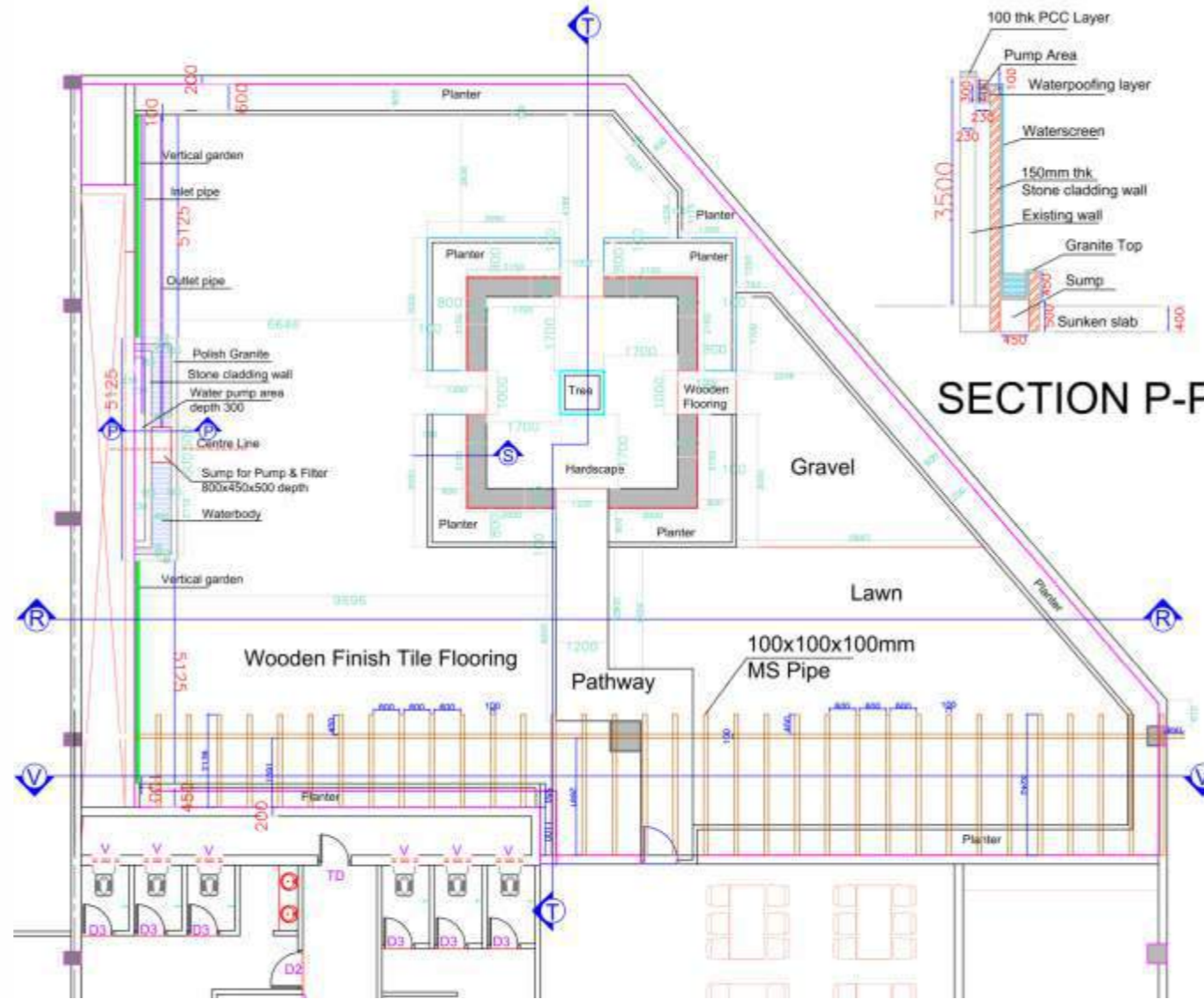

SECTION P-P

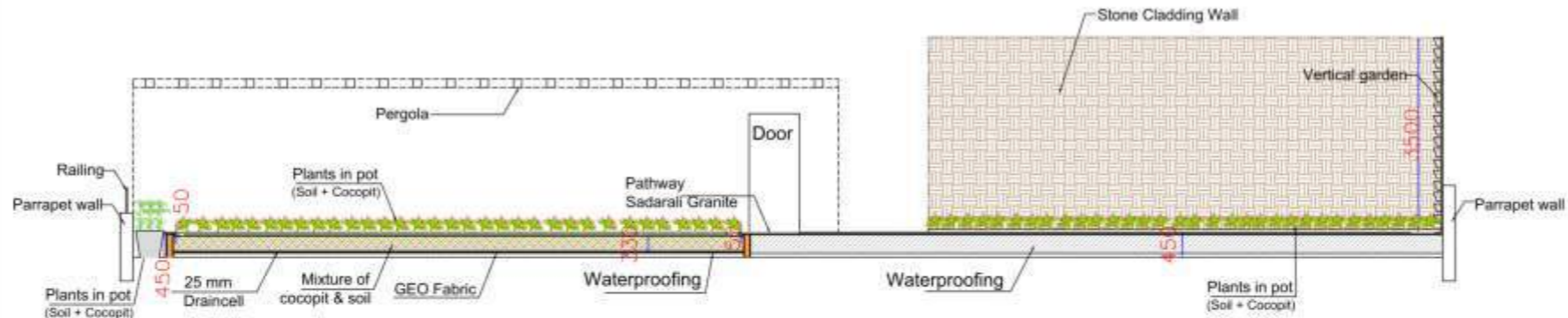

SECTION V-V

Drawing Name: Terrace Section V	Site JCB INDIA PVT.LTD., Pune	Date: 24-12-2016	North: 	Landscape design: 	<p><i>Archi Solutions</i></p> <p>42D, 1st Floor, Sri Sai Business Centre, 113, Marol Nagar, W. Ghanshyam St., Pune-411007. Tel No. 9932227271. E-mail : archi@archisolutionspune.com</p>
------------------------------------	-------------------------------------	---------------------	---	--	--

Drawings of Water Body

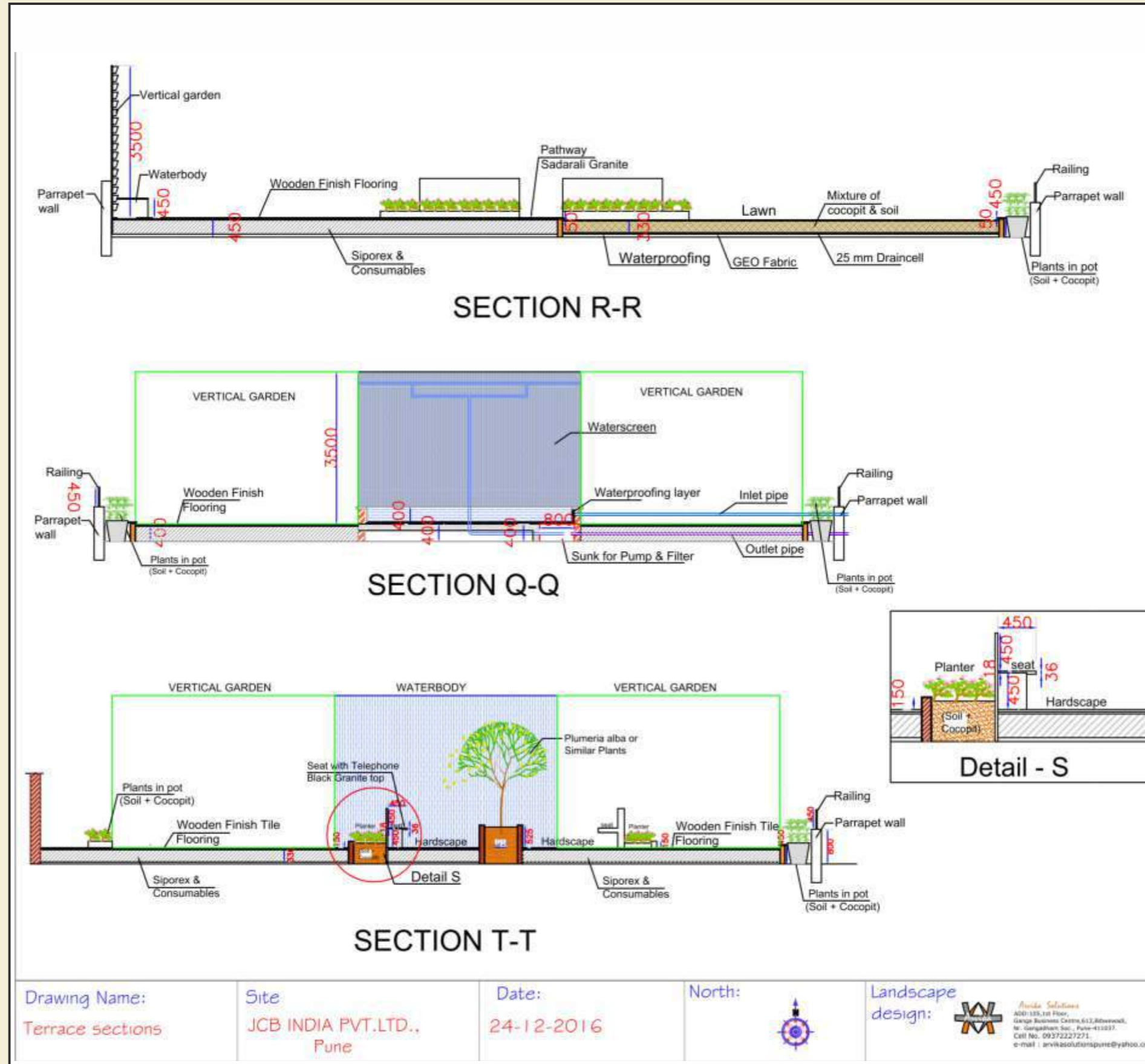

Rendered Views



Rendered Views



Actual Photographs

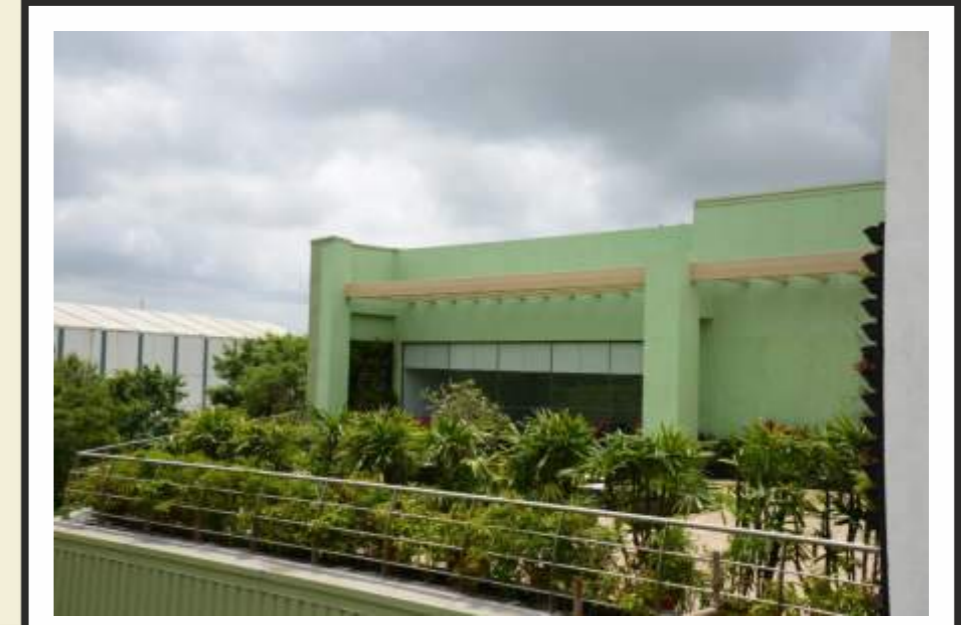

Plants to be used



Fern Green



Croton Petra



Nerium Dwarf Pink



Plumaria Alba



Hydrengia



Alpinia Variegated



Dracena Mahtma



Heliconia



Raphis Palm



Site Details

Client :Confidential

Space under scope of work : Terrace of Bungalow

Area under scope of work : 200 sqm

Scope of work : Landscape Designing

Duration : 2019



A L D S

**ARVIKA LANDSCAPE DESIGNS
SOLUTIONS PVT. LTD.**

**An ISO 9000:2015
Certified Company**

Presentation Plan - Option 01



Rendered Views - Option 01



Presentation Plan - Option 02



Rendered Views - Option 02



Presentation Plan - Option 03



Rendered Views - Option 03

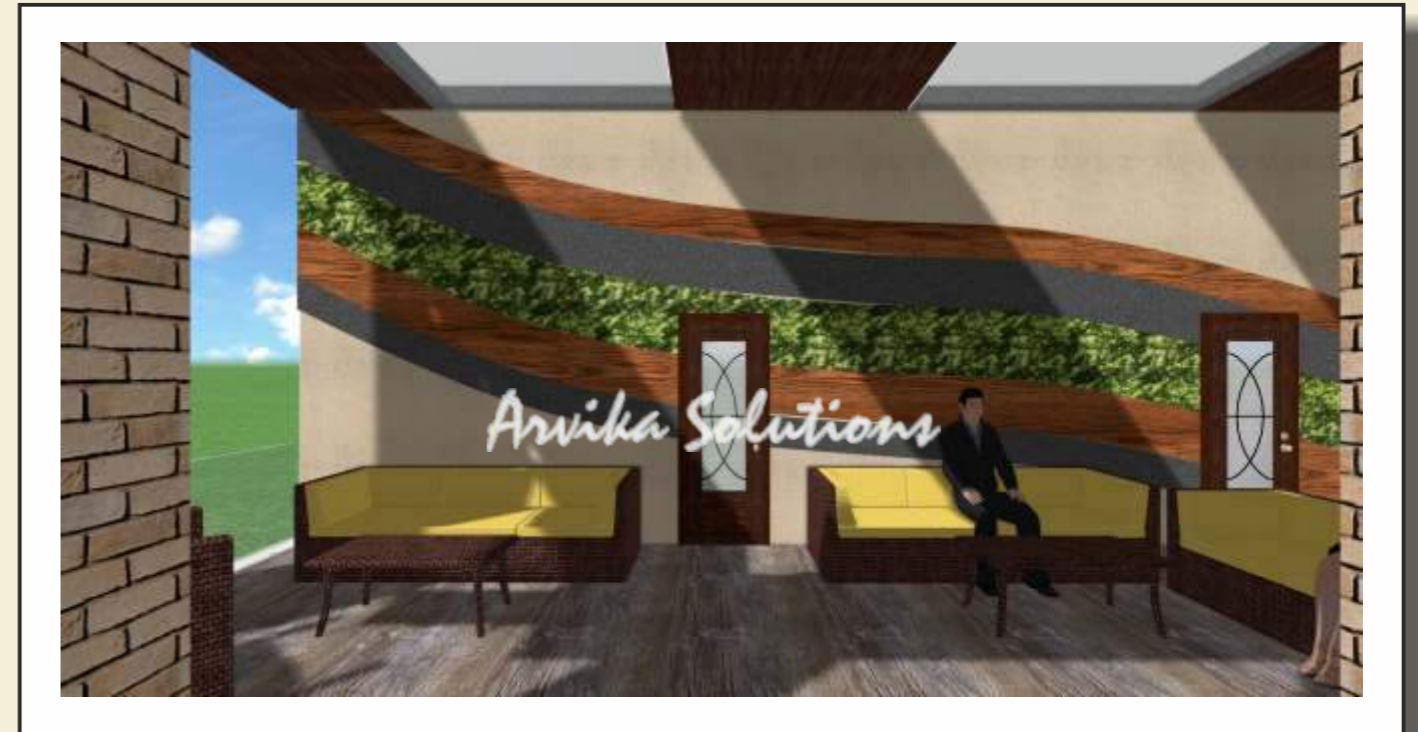



Landscape Designing Water Bodies Projects



A L D S

**ARVIKA LANDSCAPE DESIGNS
SOLUTIONS PVT. LTD.**

**An ISO 9000:2015
Certified Company**

Rendered Image

Site : Luminaz Safety G. P. L.



Actual Photograph

Site : Luminaz Safety G. P. L.

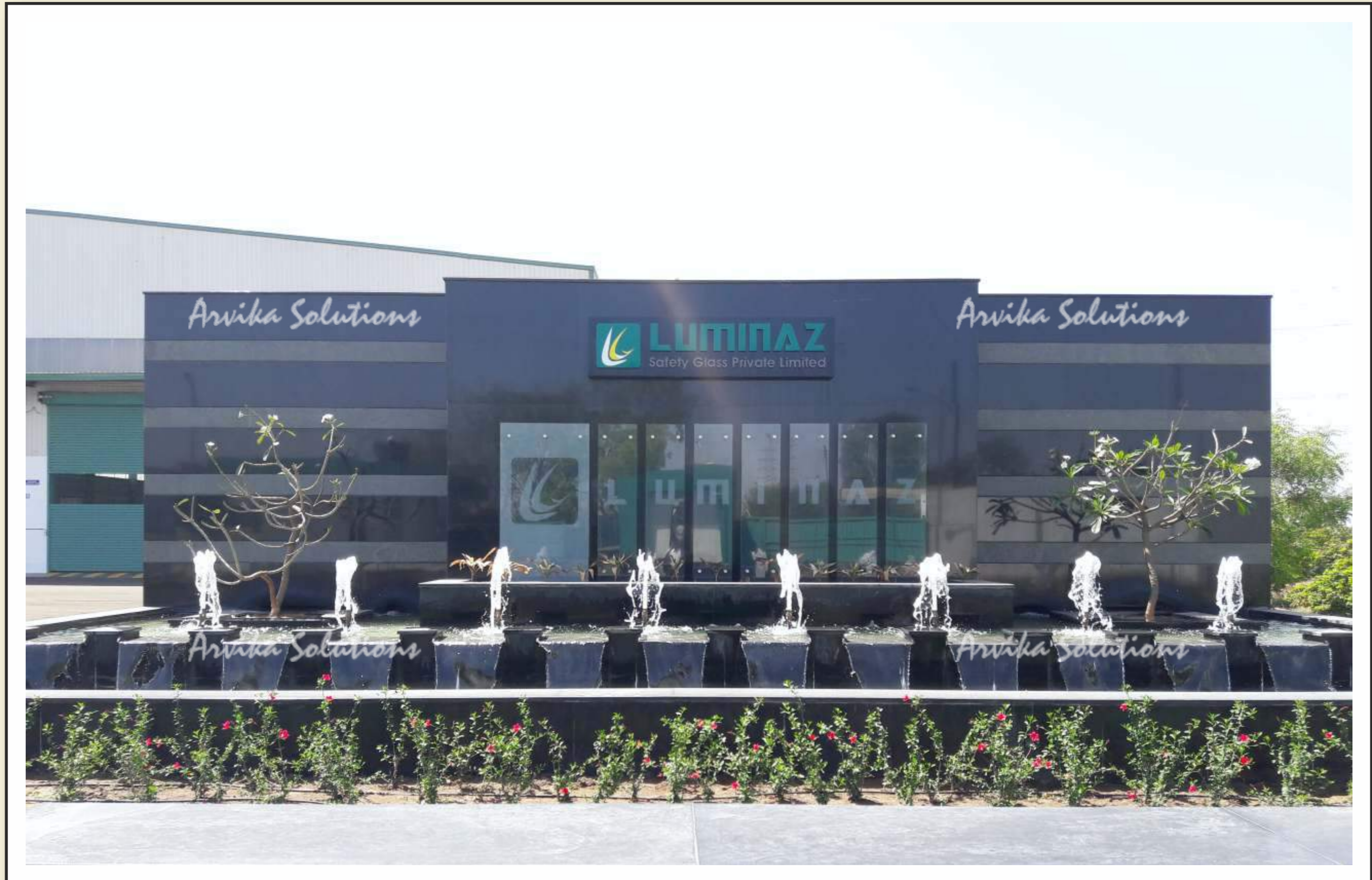

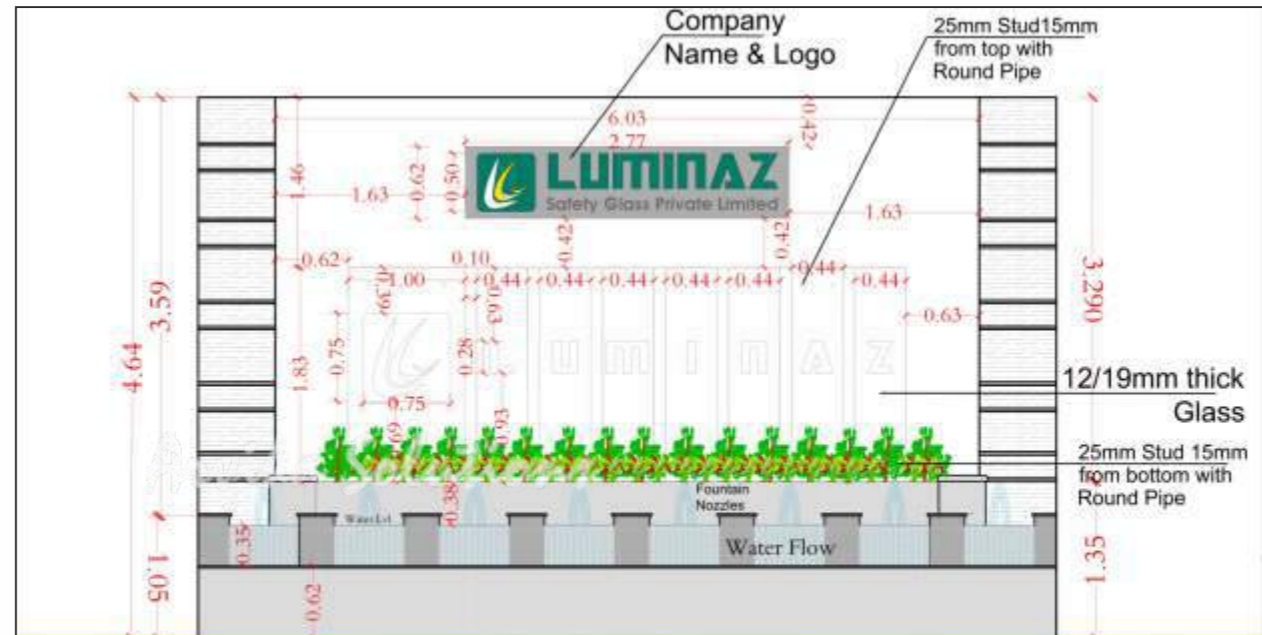

ELEVATION

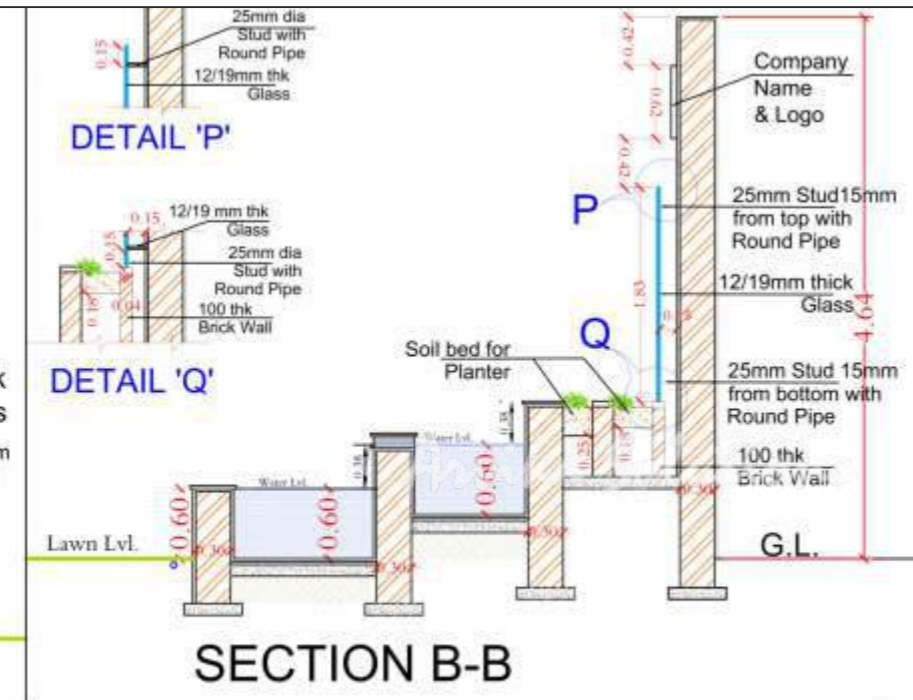

SECTION B-B

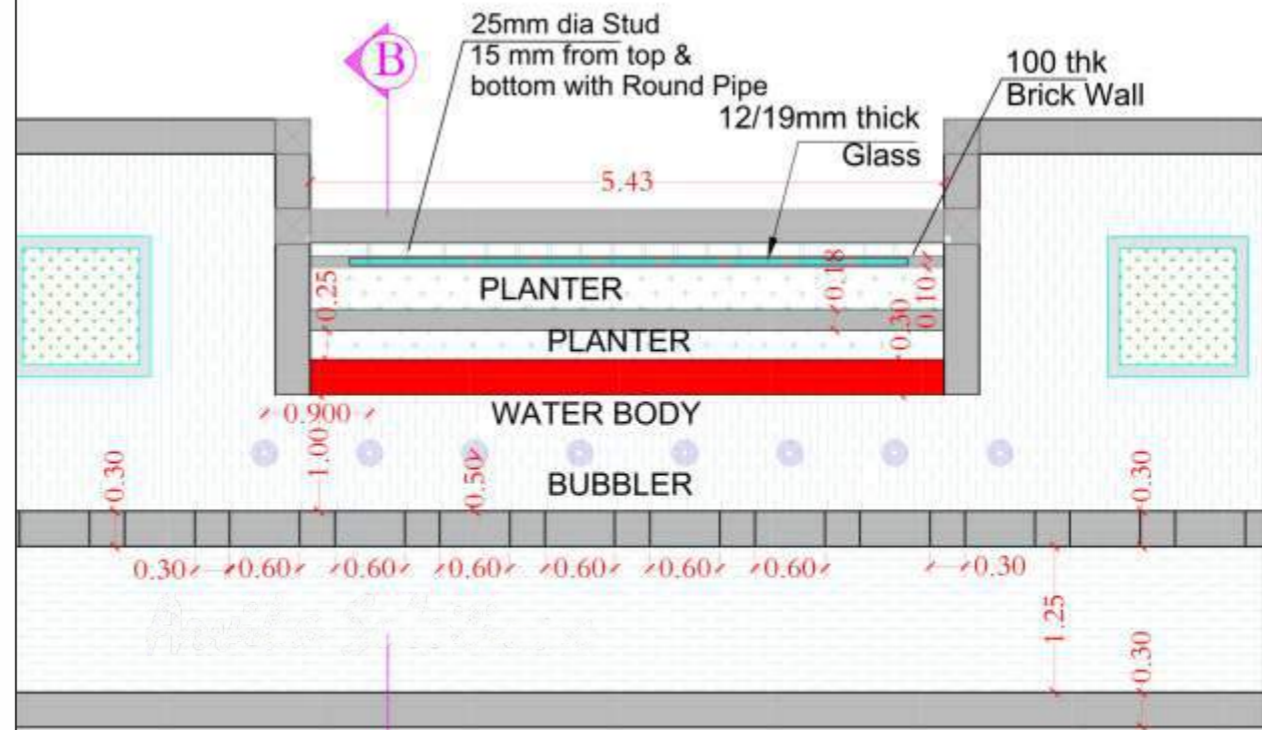

PLAN

TITLE :
**VERTICAL GLASS FITTING,
COMPANY NAME & LOGO**

CLIENT :
LUMINAZ SAFETY GLASS PVT. LTD.

SCALE :	NTS	
DATE :	16-10-17	
REVISION :		
DRAWN BY :		

Landscape Designer :
 Arvika Solutions
ADD: 105, 1st Floor,
Ganga Business Centre, 613, Bibwewadi,
Nr. Gangadham Soc., Pune-411037.
Tel. No. 020 24242462/63.
e-mail : arvikasolutionspune@yahoo.com



Actual Photograph

Site : Schindler India P.L.



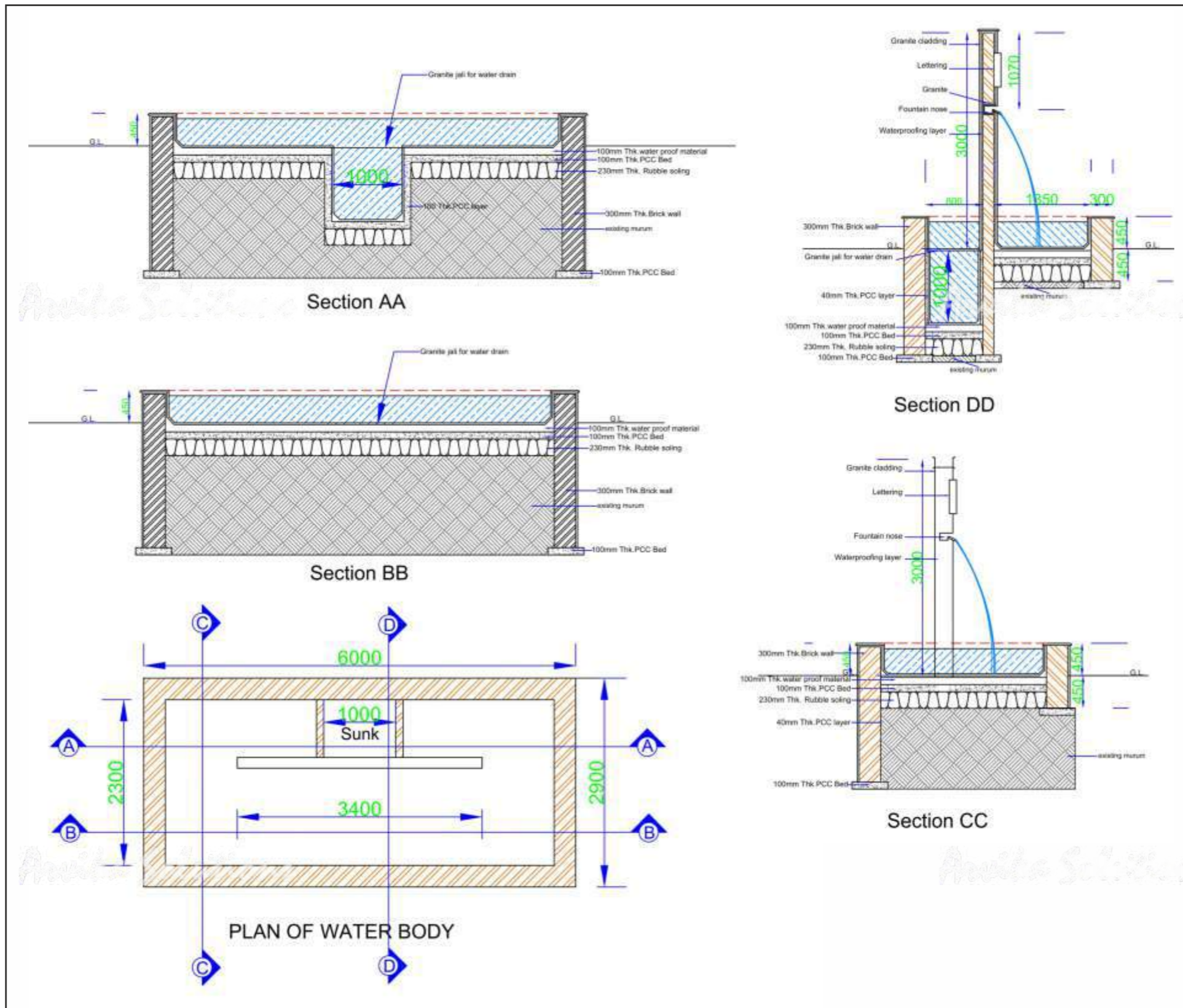

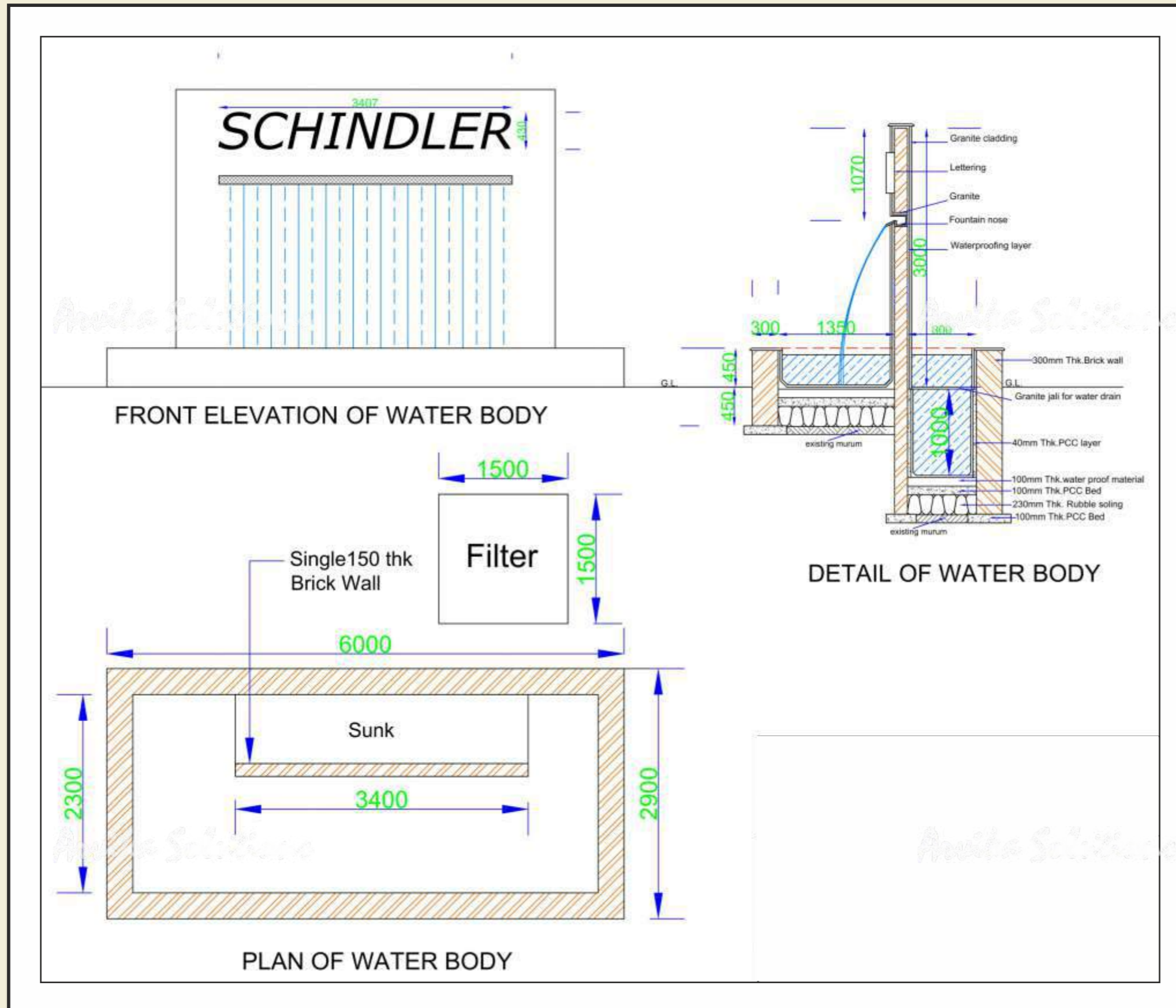

Rendered Image

Site : Vanyavillas Resort



Actual Photograph

Site : Vanyavillas Resort

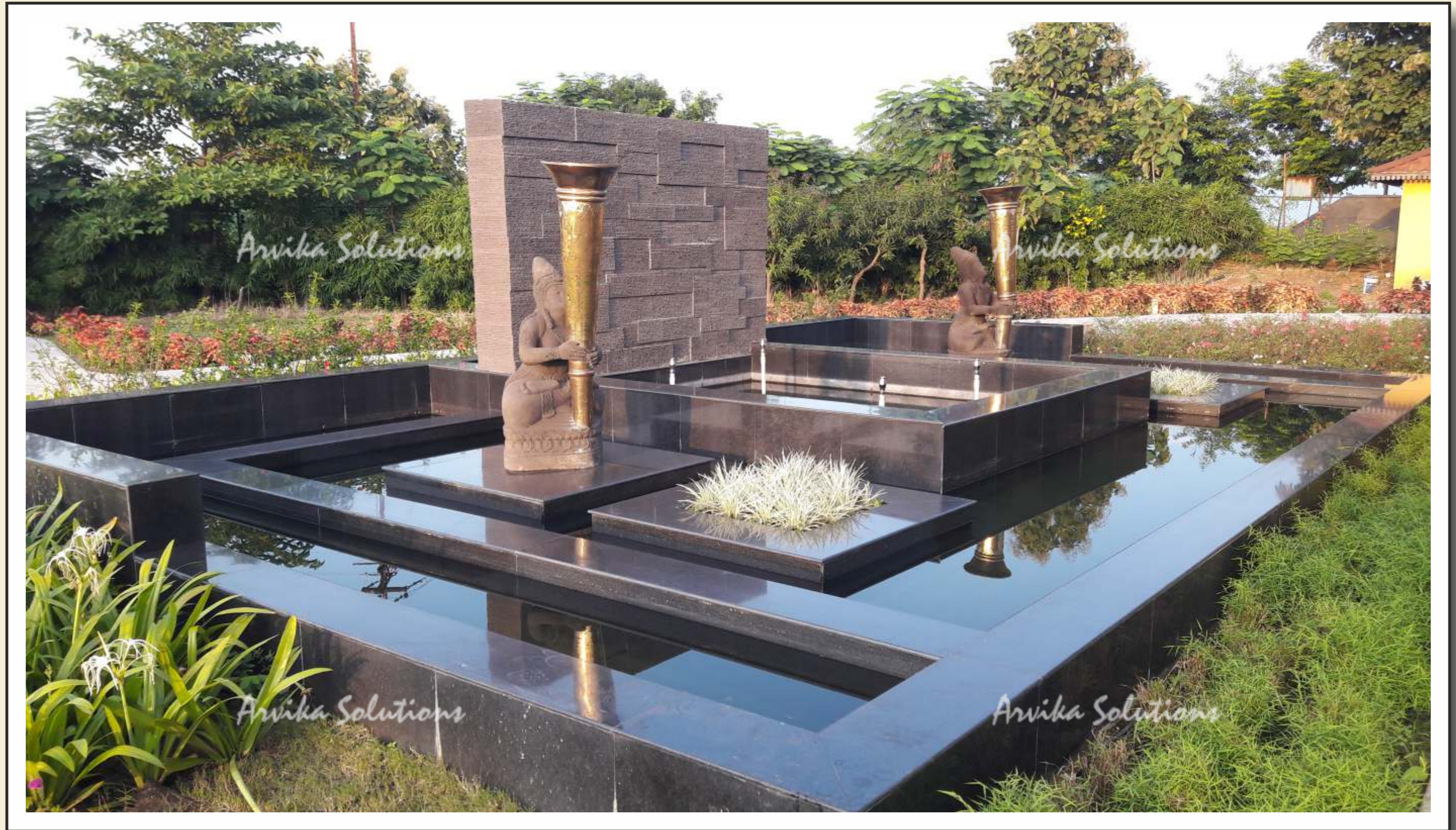

Working drawings

Site : Vanyavillas Resort

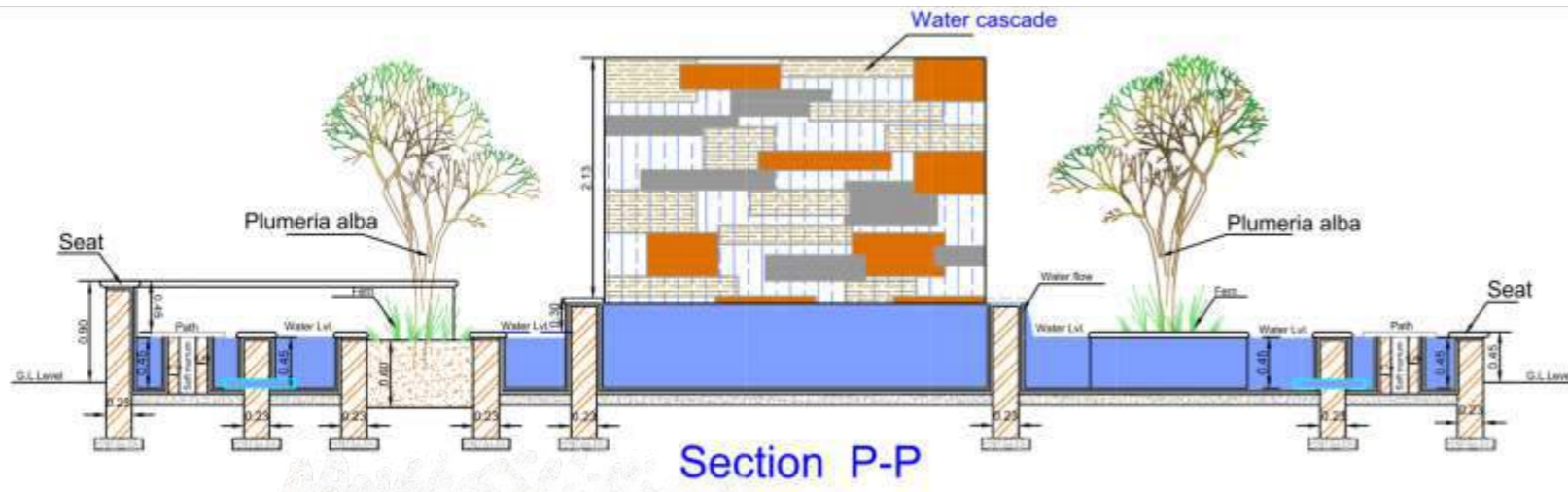

Section P-P

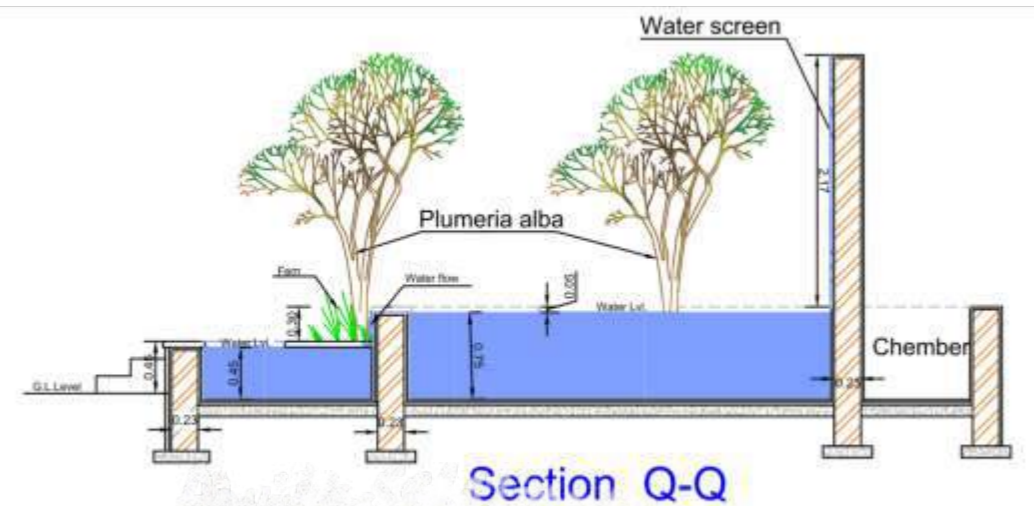

Section Q-Q

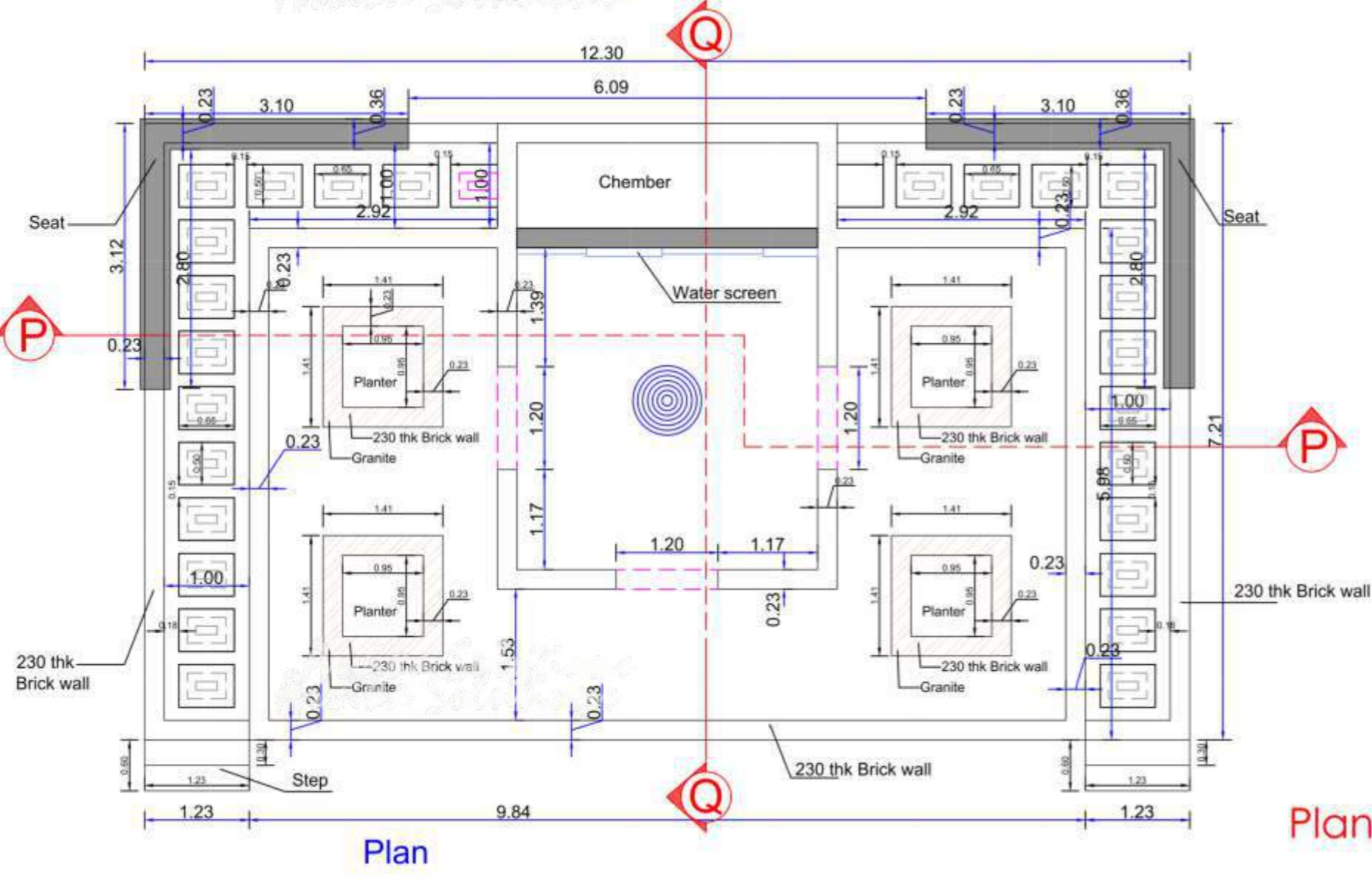

Plan

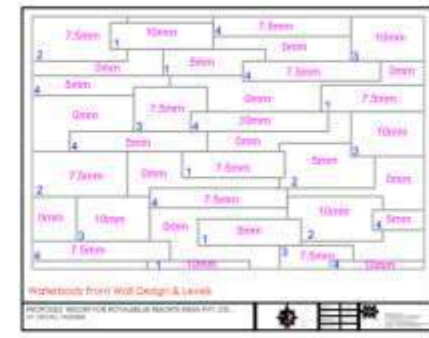

Plan for Water body Lineout & Details

Rendered Image

Site : Vanyavillas Resort



Actual Photograph

Site : Vanyavillas Resort

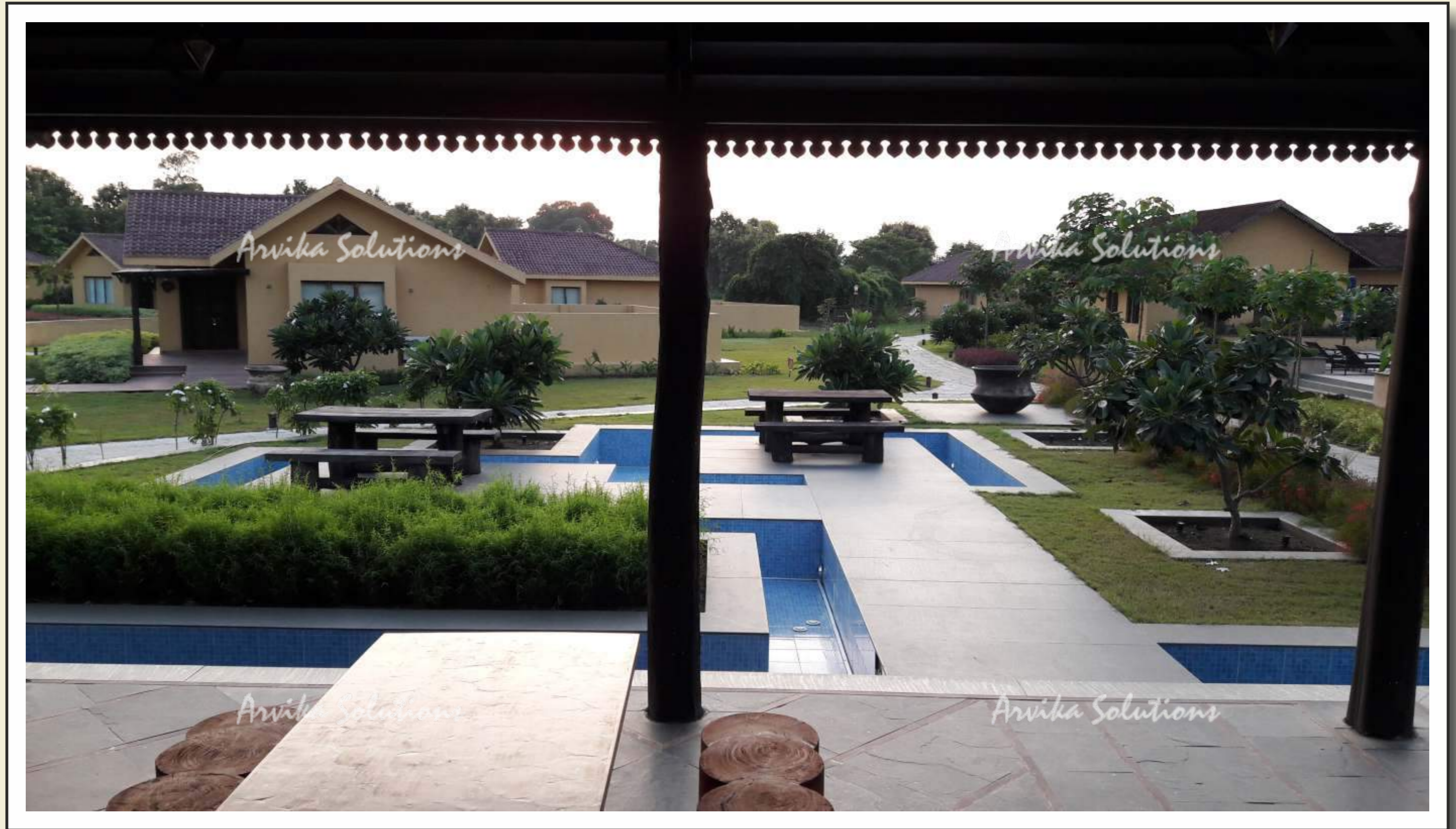

Working Drawings

Site : Vanyavillas Resort

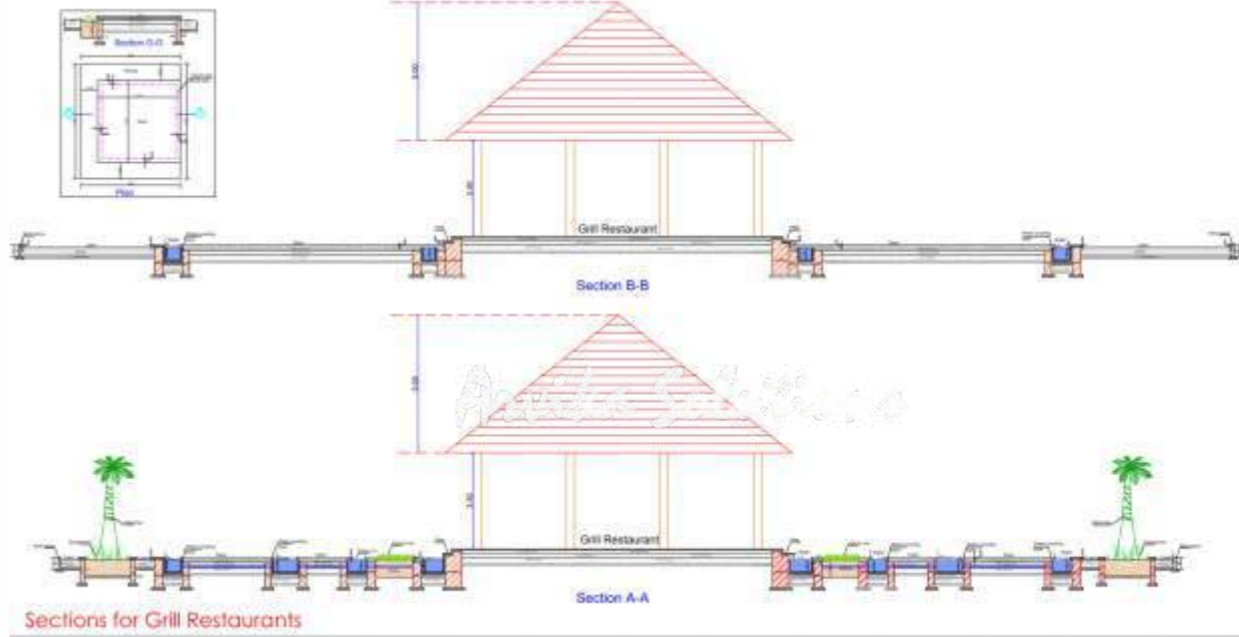
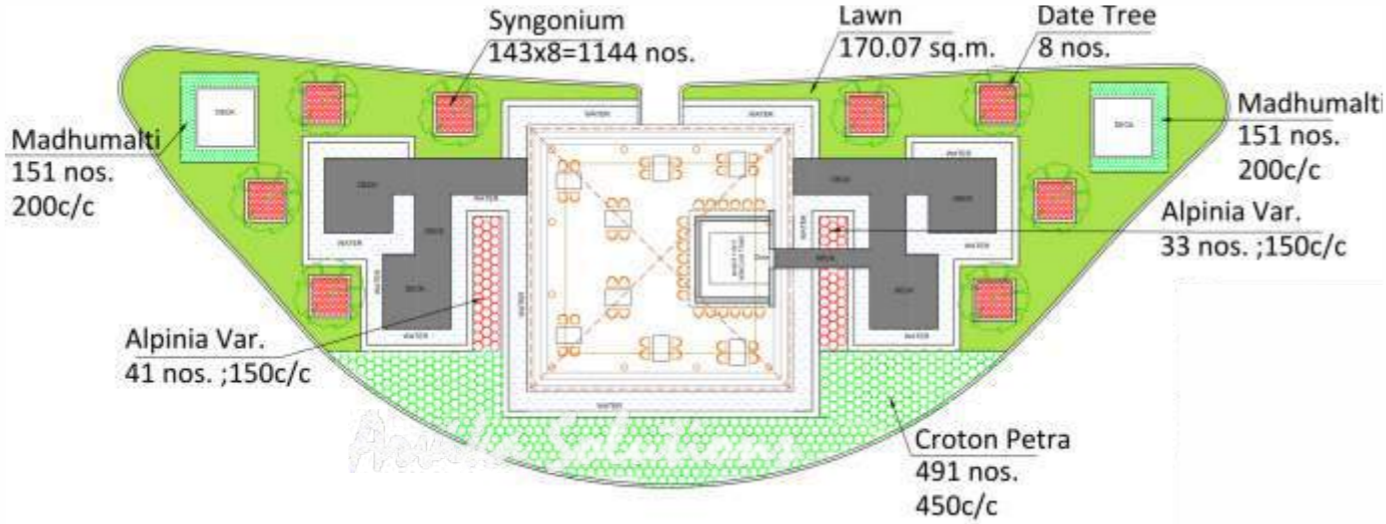
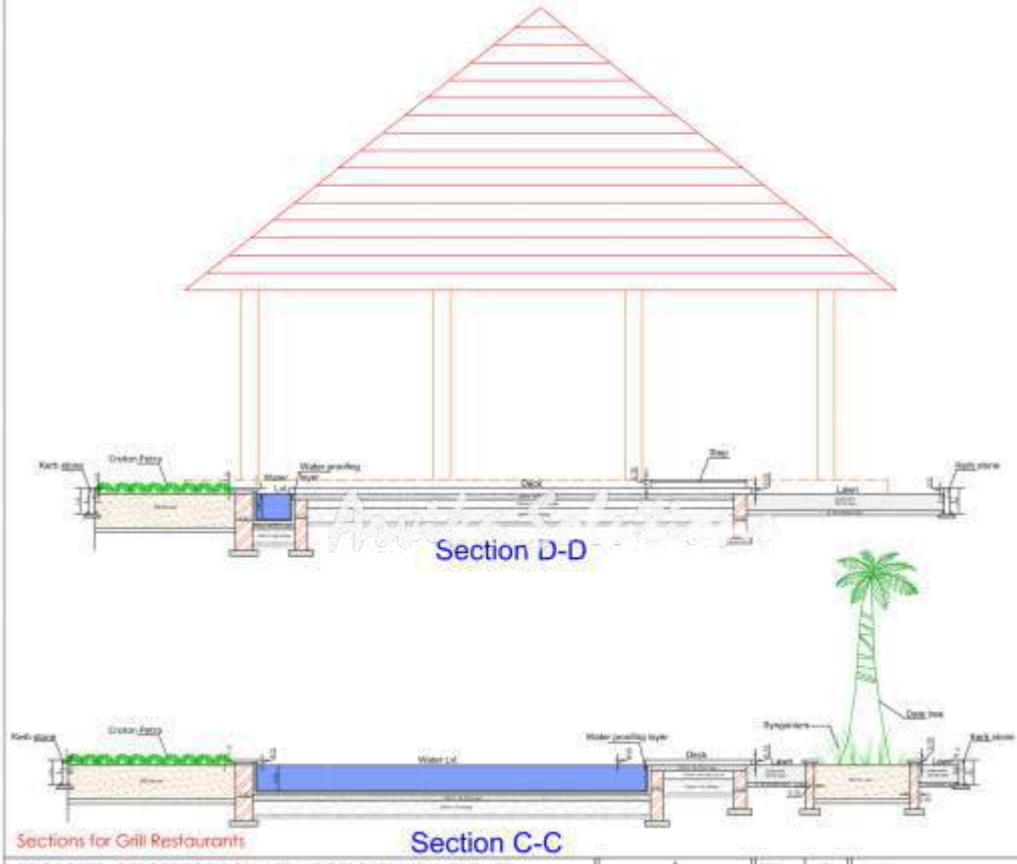
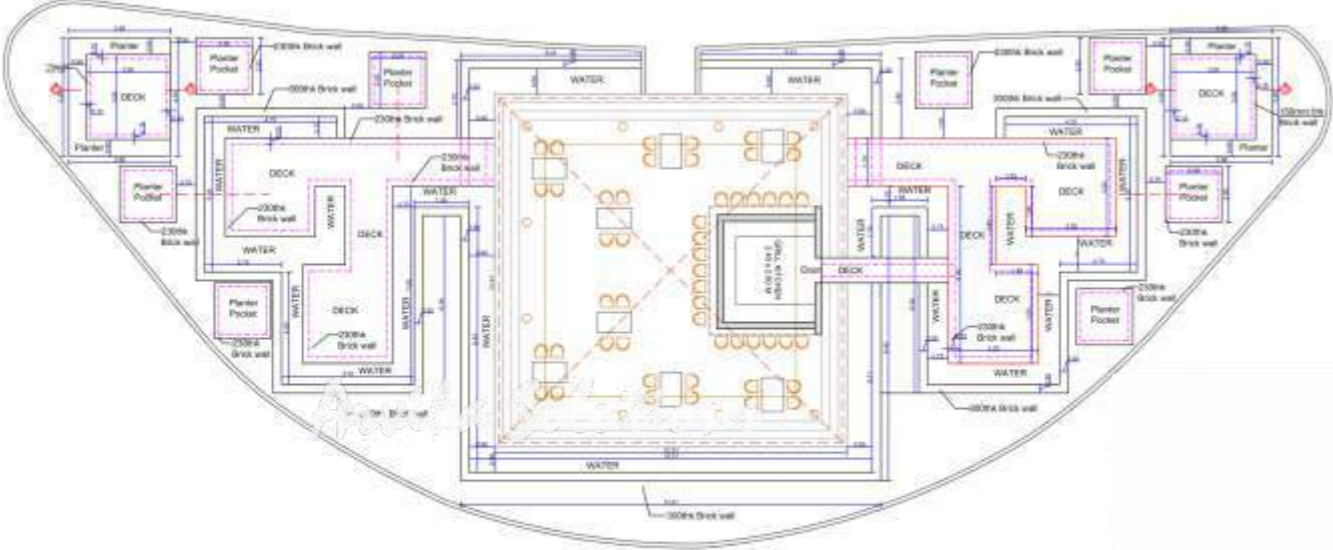

Rendered Image

Site : Vanyavillas Resort



Actual Photograph

Site : Vanyavillas Resort



Working Drawings

Site : Vanyavillas Resort

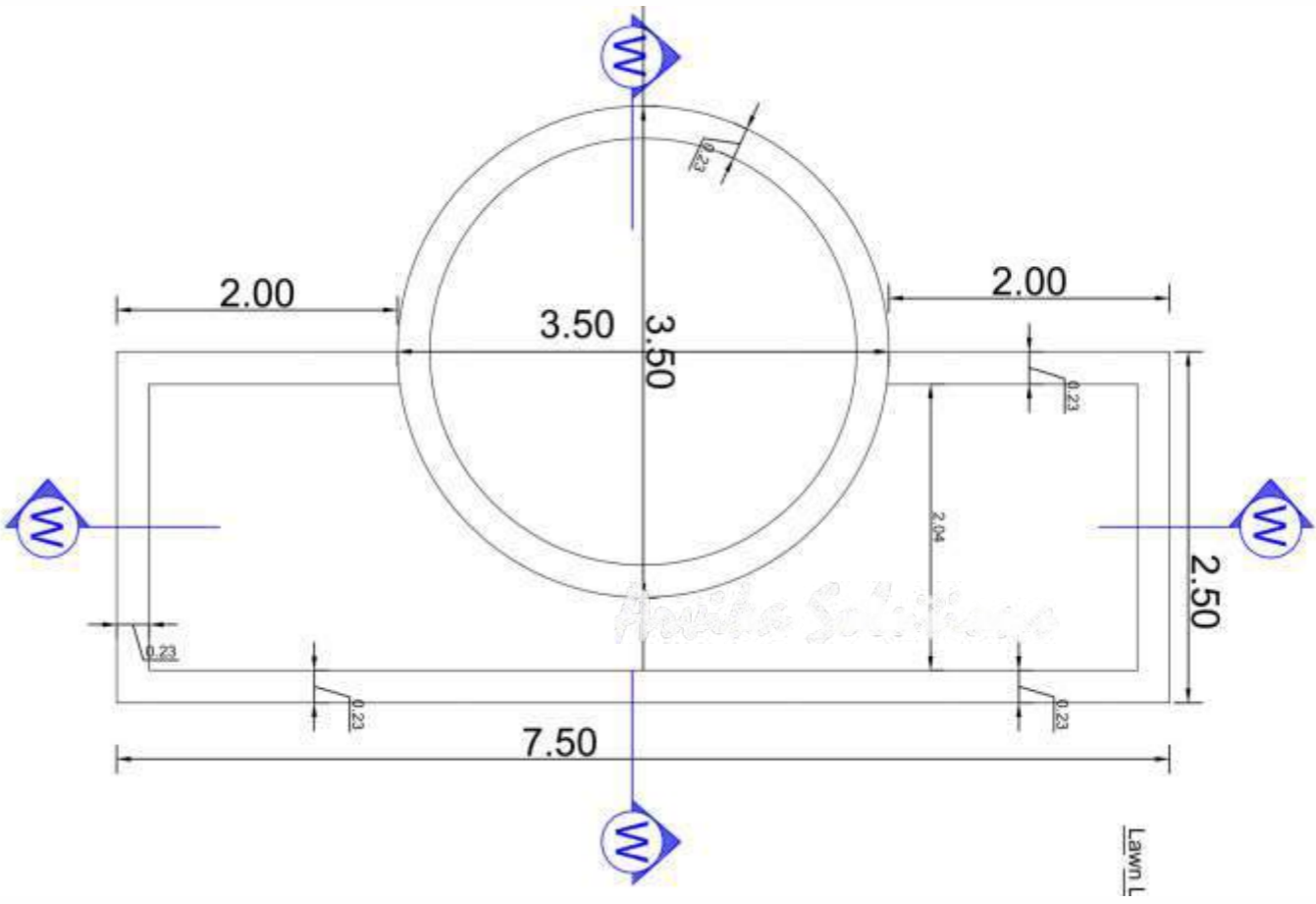
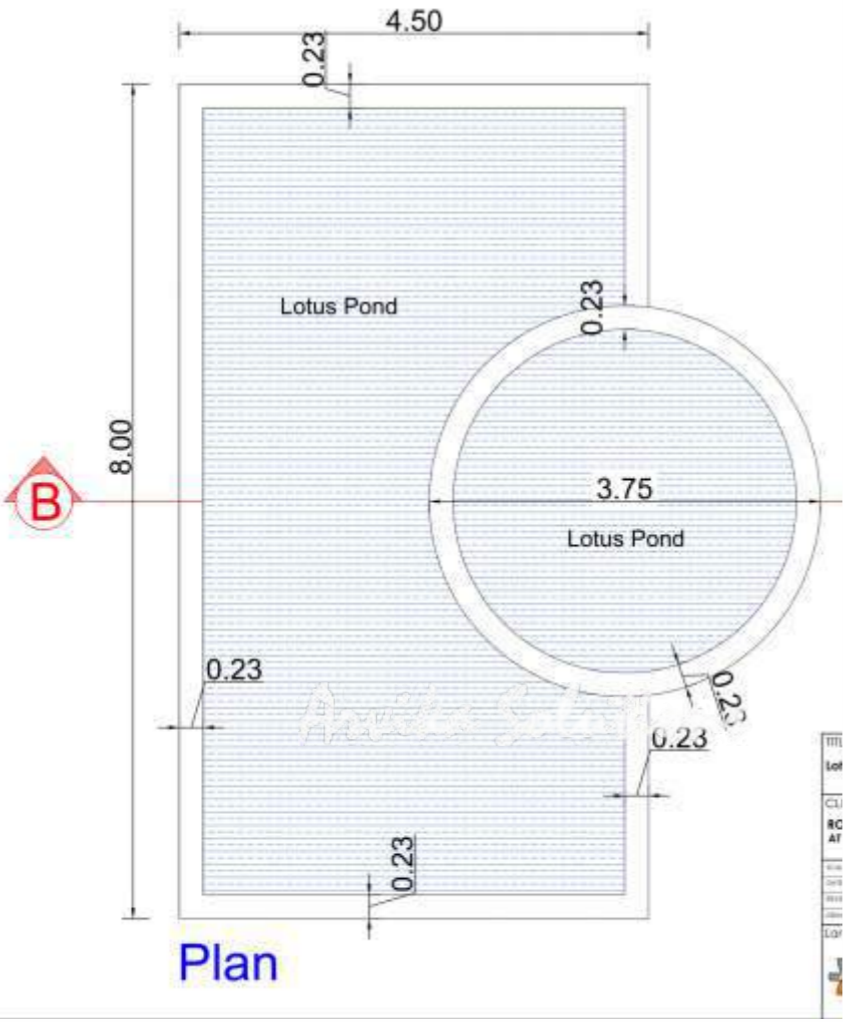
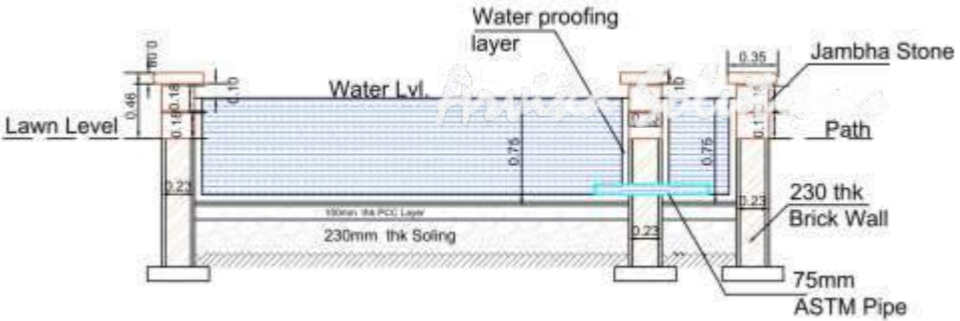
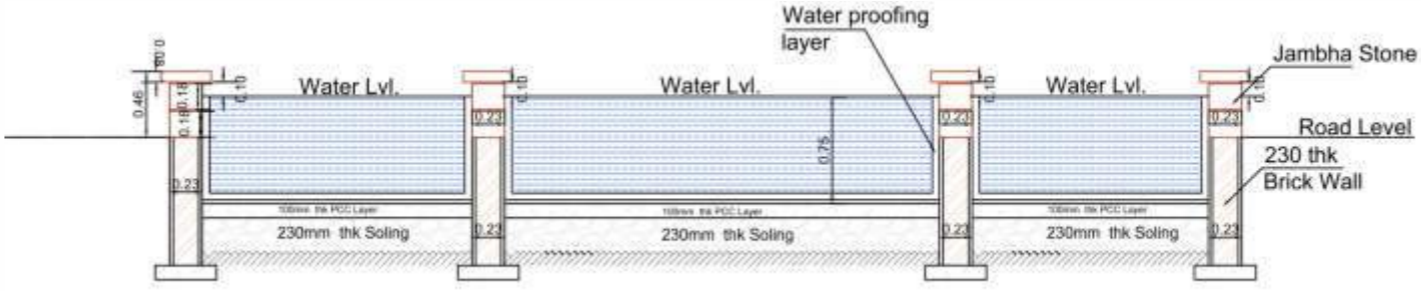
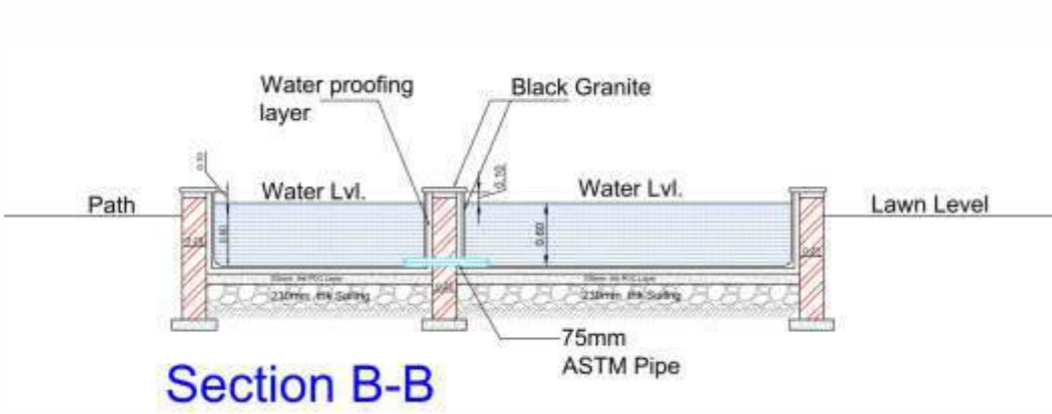

Rendered Images

Site : Private Residence



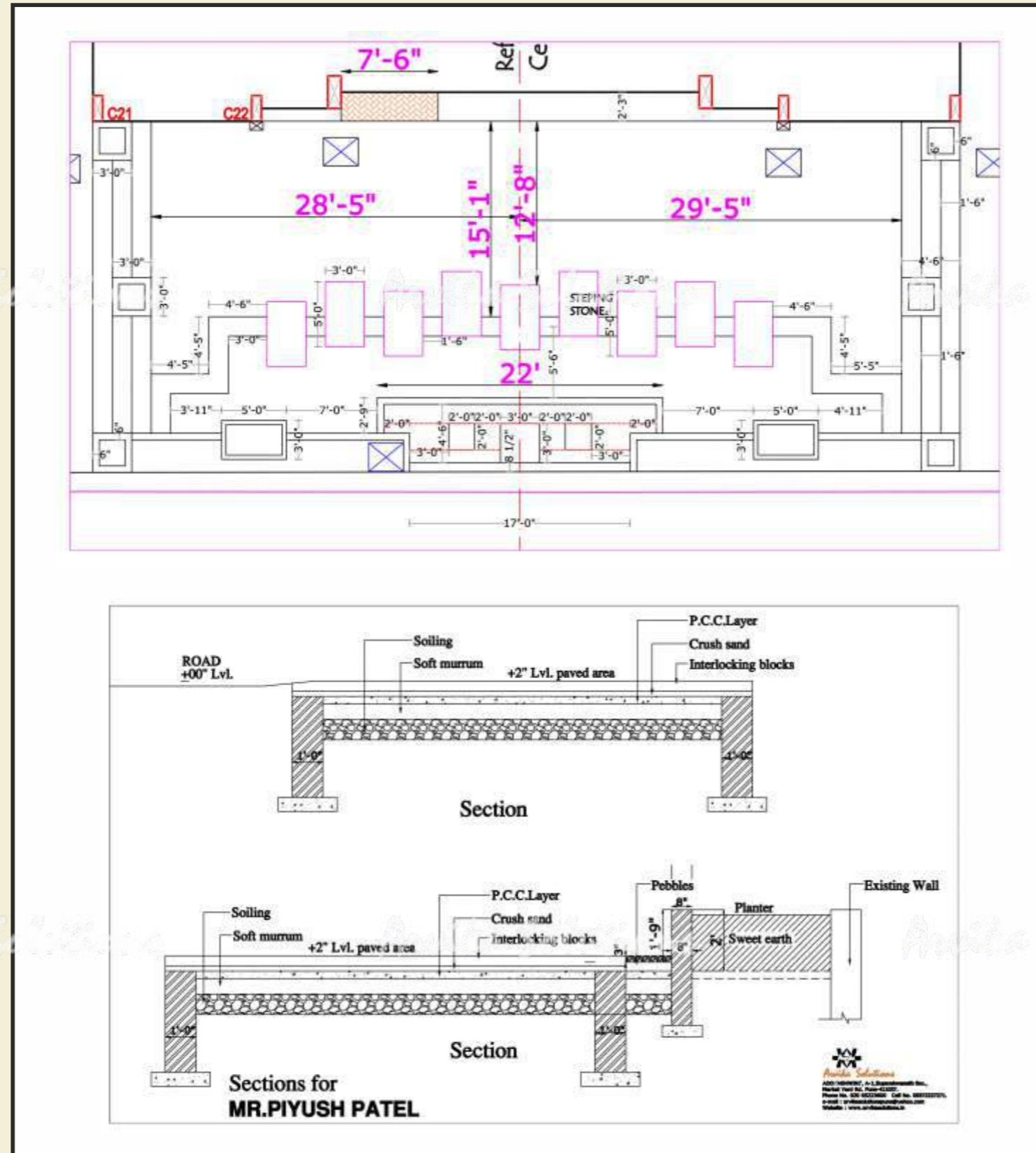

Actual Photograph

Site : Private Residence



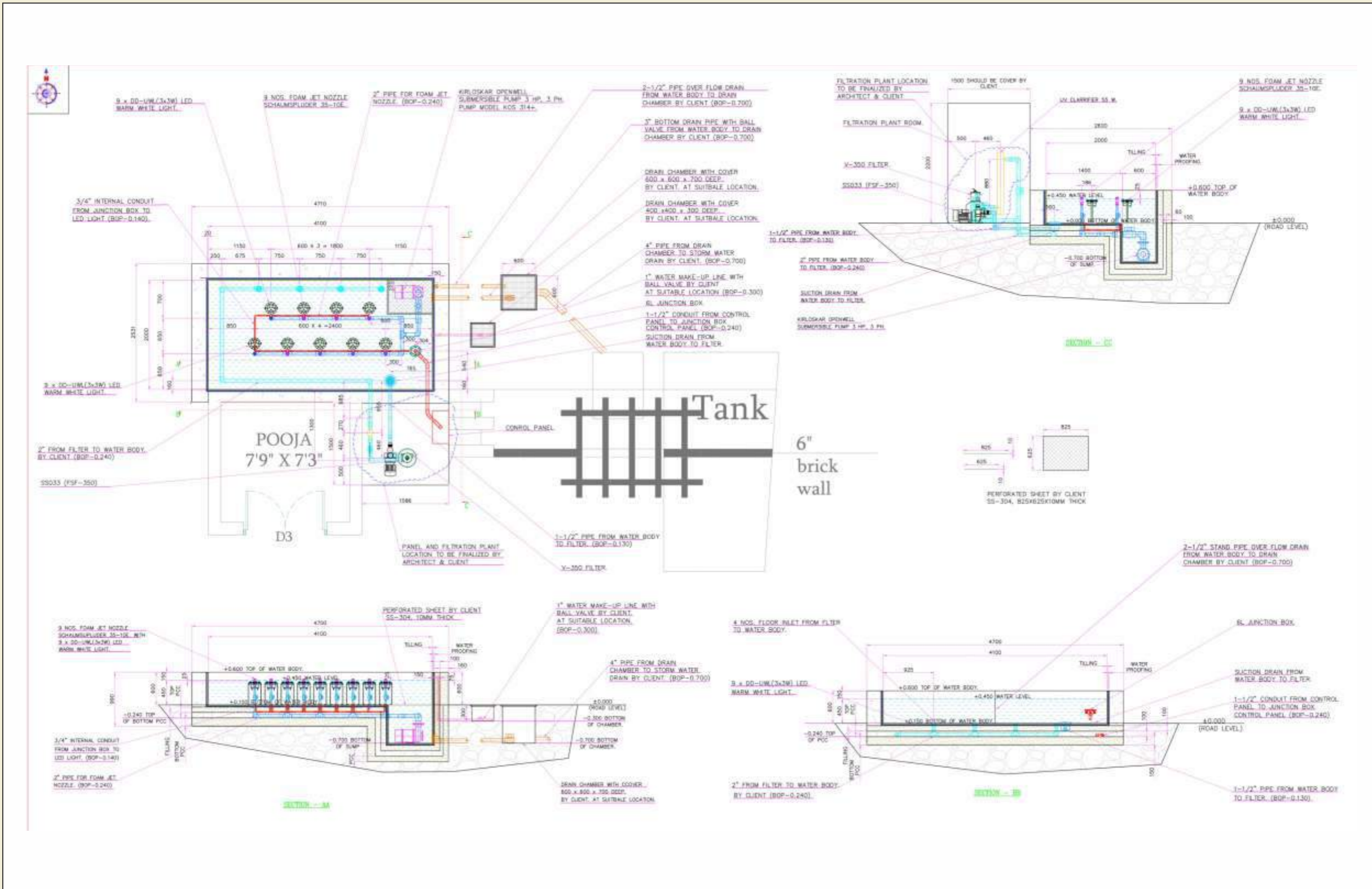

Rendered Images

Site : Public Garden



Working Drawing

Site : Public Garden

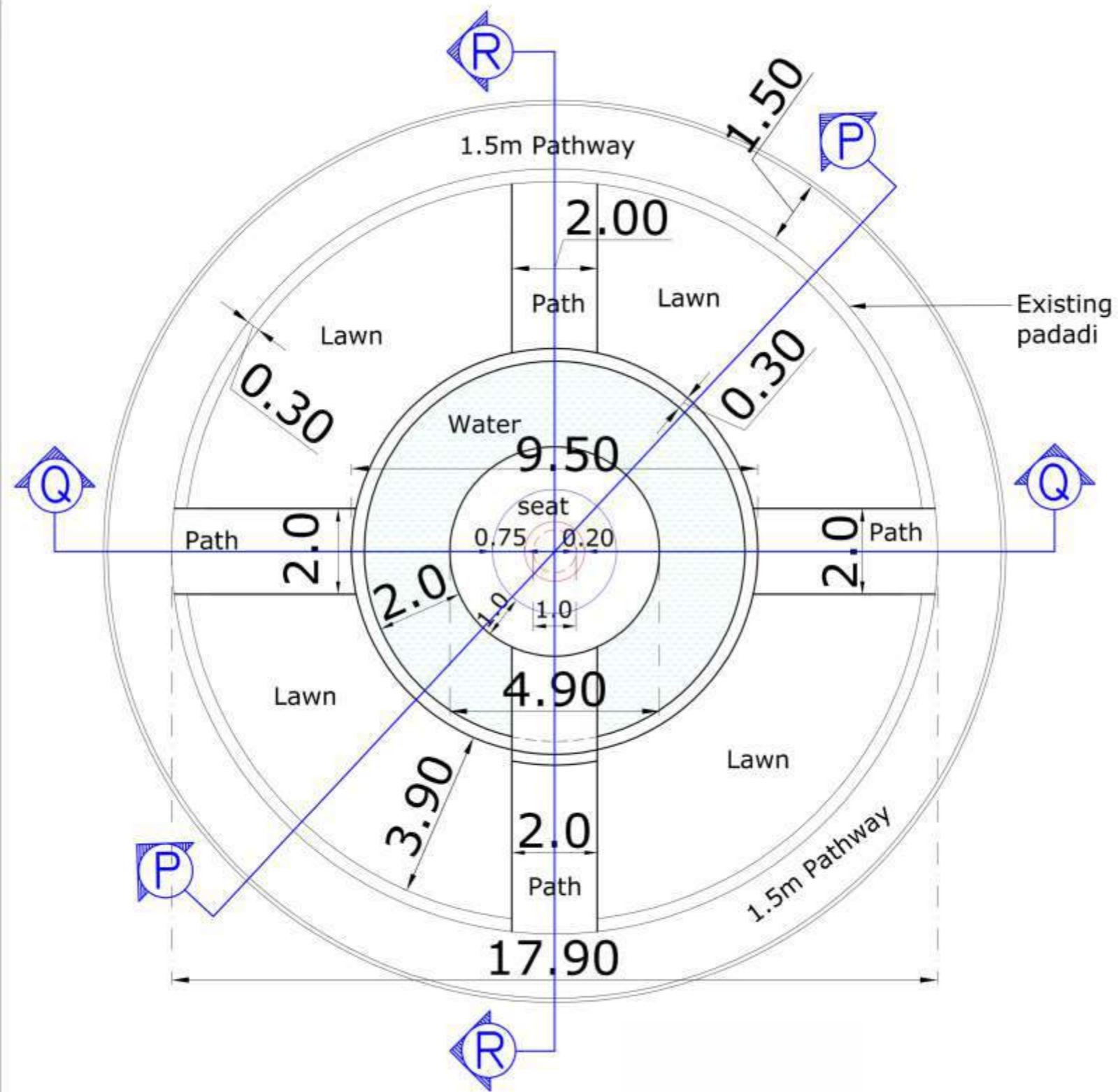

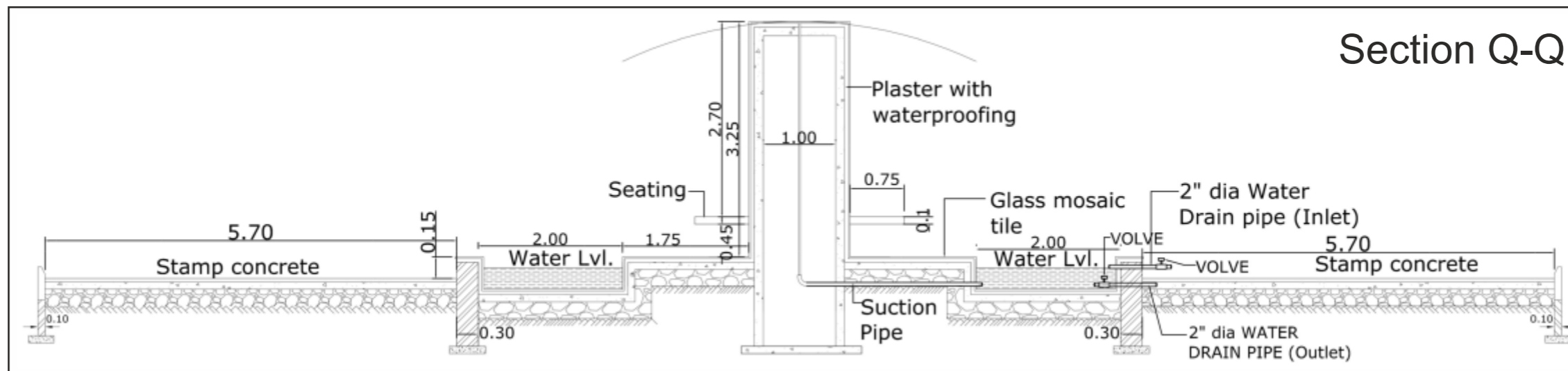
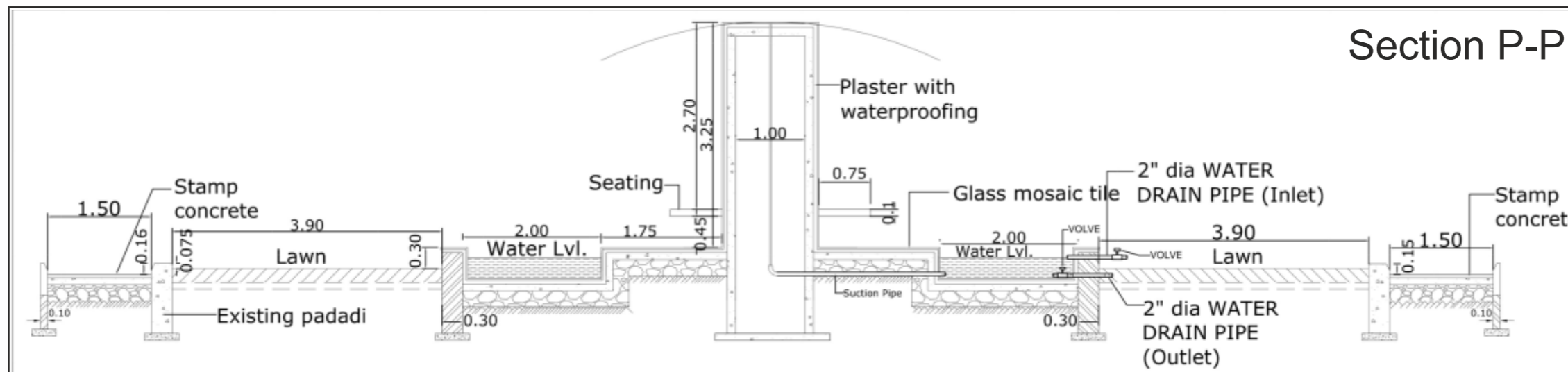
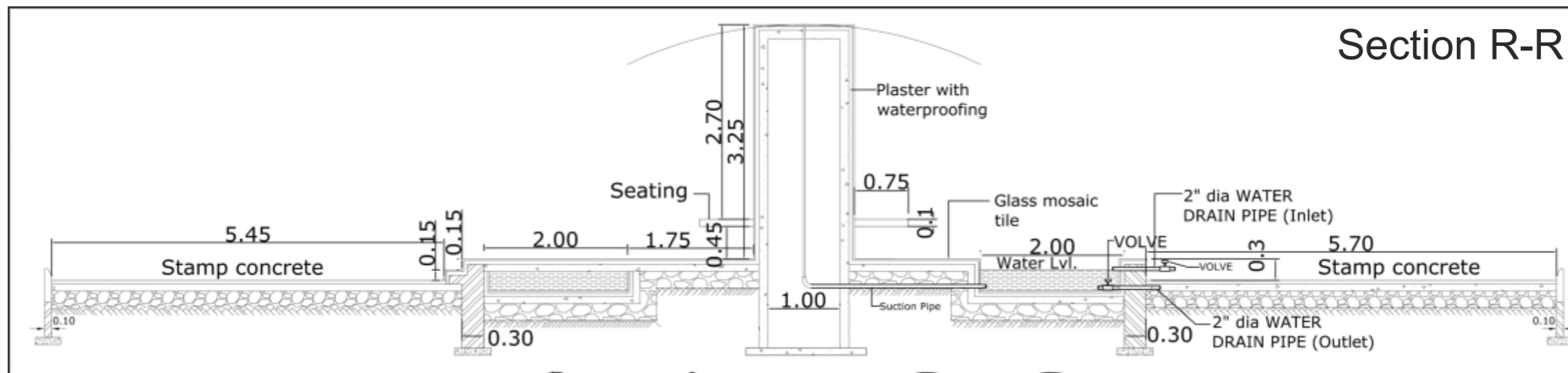

Rendered Image

Site : JCB India P.L.

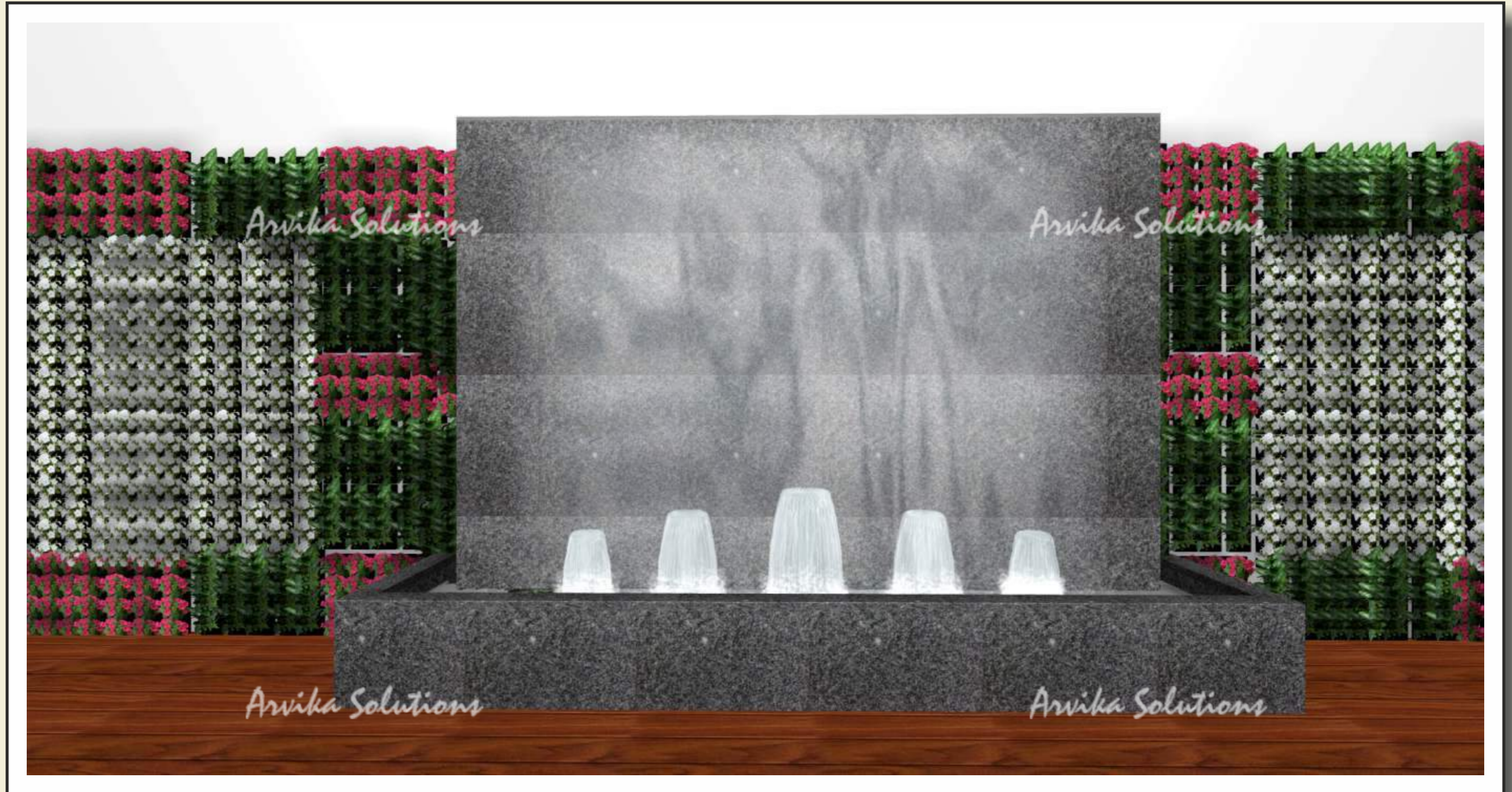

Actual Photograph

Site : JCB India P.L.



